

# Operating Instructions MAGSTOP Traffic Barrier MIB 30/40 MLC Controller Unit

Version 2004\_05

**TABLE OF CONTENTS**

**1.0 SAFETY ..... 5**

1.1 SAFETY SYMBOLS USED IN THIS HANDBOOK ..... 5

1.2 GENERAL SAFETY INFORMATION ..... 6

1.3 INTENDED USE ..... 6

1.4 WARNING AND SAFETY SIGNAGE ..... 6

1.5 SAFETY REQUIREMENTS ..... 7

1.6 OPERATIONAL SAFETY ..... 8

1.7 TECHNICAL DEVELOPMENTS ..... 9

1.8 WARRANTY ..... 9

**2.0 INSTALLATION ..... 10**

2.1 GUIDELINES FOR FOUNDATION ..... 10

2.1 MOUNTING THE HOUSING TO THE GROUND ..... 11

**3.0 OPERATING THE MIB\* BARRIER GATE ..... 14**

**4.0 MLC CONTROLLER ..... 15**

4.1 GENERAL ..... 15

4.1 MLC CONTROLLER SETUP ..... 16

4.2 DISPLAY INFORMATION ..... 17

4.3 PROGRAMMING AND READING THE OPERATING DATA ..... 18

4.3.1.1 PROGRAMMING MODES SHORT DESCRIPTION ..... 19

4.3.1.2 SHORT DESCRIPTION OF THE GENERAL OPERATING DATA: ..... 19

**5.0 PROGRAMMING MODES ..... 20**

5.1 AVAILABLE PROGRAM MODES AND FUNCTIONS ..... 21

5.1.1 PROGRAM 1 (MODE 1): ..... 22

5.1.2 PROGRAM 2 (MODE 2): ..... 23

5.1.3 PROGRAM 3 (MODE 3): ..... 24

5.1.4 PROGRAM 4 (MODE 4): ..... 25

5.1.5 PROGRAM 5 (MODE 5): ..... 26

5.1.6 PROGRAM 6 (MODE 6): ..... 28

5.1.7 PROGRAM 7 (MODE 7): ..... 30

5.1.8 PROGRAM 8 (MODE 8): ..... 31

**6.0 TORQUE TIME SETTINGS ..... 32**

6.1 HOW TO ADJUST THE TORQUE TIME: ..... 32

**7.0 HOLD OPEN TIMER ..... 33**

7.1 HOW TO ADJUST THE HOLD OPEN TIMER: ..... 33

**8.0 LOOP DETECTOR SENSITIVITY ..... 34**

8.1 HOW TO ADJUST THE LOOP A SENSITIVITY: ..... 34

**9.0 CONFIGURING THE LOOP DETECTORS ..... 35**

9.1 SAFETY/CLOSING LOOP A ..... 35

# Operation Instructions

9.2 LOOP A MODE FUNCTION .....	36
9.2.1 Detector Mode A .....	36
9.2.2 Directional Logic Loop A .....	36
9.3.1 Detector mode B .....	39
9.3.2 Directional Logic Loop B .....	39
<b>10.0 LOOP FREQUENCY .....</b>	<b>42</b>
10.1 HOW TO VIEW THE LOOP FREQUENCY: .....	42
10.2 HOW TO CHANGE THE LOOP FREQUENCY: .....	43
<b>11.0 RELAY K1 OUTPUT .....</b>	<b>44</b>
<b>12.0 ERROR CODE .....</b>	<b>46</b>
<b>13.0 LANGUAGE SETTING .....</b>	<b>46</b>
<b>14.0 EXTENDED MENU SETTINGS: .....</b>	<b>47</b>
14.1 ADJUSTING THE SAFETY ANGLE: .....	48
14.2 OPERATING HOUR DISPLAY: .....	49
14.3 GATE CYCLE COUNTER: .....	49
14.4 READING THE BRAKE POINTS: .....	50
14.5 RESETTING THE BARRIER AFTER POWER FAILURE: .....	50
14.6 TEST MODE .....	51
<b>15.0 INSTALLING THE INDUCTION LOOPS .....</b>	<b>53</b>
15.1 GENERAL INDUCTION LOOP FUNCTIONALITY .....	53
15.2 LOOP INDUCTANCE .....	53
15.2.1 INDUCTANCE .....	53
15.2.2 VEHICLE DETECTION .....	54
15.2.3 WIRE TURNS REQUIRED FOR LOOPS .....	54
15.2.4 LOOP INDUCTANCE CALCULATIONS .....	55
15.3 LOOP DETECTOR SENSITIVITY .....	56
15.4 INSTALLING A INDUCTION LOOP .....	56
15.4.1 USAGE OF PRE-MANUFACTURED LOOPS .....	56
15.4.2 SELF-MADE LOOPS .....	57
15.4.3 LOOP LEAD WIRES .....	57
15.4.4 HOW DEEP SHOULD THE LOOP WIRES BE INSTALLED? .....	58
15.4.5 LOOP DISTANCE FROM OBJECTS: .....	59
<b>16.0 COMMISSIONING .....</b>	<b>ERROR! BOOKMARK NOT DEFINED.</b>
16.1 COMMISSIONING PROCEDURE .....	60
16.3 STANDARD CONFIGURATION: .....	61
16.3.1 PARKING OR ACCESS CONTROL CONFIGURATION: .....	61
<b>17.0 INSTALLATION EXAMPLE: .....</b>	<b>62</b>
17.1 FREE EXIT OR ENTRY CONFIGURATION: .....	62
17.1.1 FREE ENTRY OR EXIT LANE LAYOUT .....	63
17.1.2 FREE ENTRY OR EXIT WIRING DIAGRAM: .....	64
17.2 ENTRY OR EXIT WITH ACCESS CONTROL: .....	65
17.2.1 ACCESS CONTROL LANE LAYOUT .....	66
17.2.2 ACCESS CONTROL LANE WIRING DIAGRAM .....	67
17.3 ACCESS CONTROL ONE DIRECTION FREE IN/OUT OTHER DIRECTION .....	68

17.3.1 ACCESS CONTROL IN FREE OUT LANE LAYOUT .....	69
17.3.2 ACCESS CONTROL IN FREE OUT LANE WIRING DIAGRAM .....	70
17.4 MASTER SLAVE CONFIGURATION .....	71
17.4.1 MASTER/SLAVE LANE LAYOUT .....	73
17.4.2 MASTER SLAVE WIRING DIAGRAM .....	74
<b>18.0 MIB* BARRIER WITH BOOM LOCK MECHANISM .....</b>	<b>75</b>
<b>19.0 MIB* BARRIER WITH BOOM LIGHTS .....</b>	<b>76</b>
<b>20.0 MECHANICAL OPERATION .....</b>	<b>77</b>
20.1 SPRING BALANCE .....	77
20.2 BARRIER ARM SUPPORT .....	79
20.2.1 PENDULUM SUPPORT .....	79
20.2.2 SUPPORT POST .....	79
<b>21.0 TROUBLESHOOTING .....</b>	<b>ERROR! BOOKMARK NOT DEFINED.</b>
21.1 ADJUSTING THE BOOM POSITION SENSOR .....	81
21.2 BOOM SENSOR OUT OF ADJUSTMENT .....	84
21.3 LOOP DETECTOR ERROR .....	87
21.4 GATE DOES NOT CLOSE .....	88
21.5 GATE DOES NOT OPEN .....	89
21.6 HOW TO CHANGE FROM RIGHT-HANDED GATE TO LEFT- HANDED? .....	90
<b>22.0 TECHNICAL DATA .....</b>	<b>92</b>
22.1 MAGSTOP BARRIERS .....	92
22.2 CONTROLLER .....	92
<b>23. MAINTENANCE .....</b>	<b>94</b>
23.1 CHANGING THE RUBBER END STOP .....	94
23.2 CHECKING THE EXTERIOR OF CABINET .....	94
23.3 CHECK THE BARRIER ARM AND THE ATTACHMENT KIT .....	94
23.4 CHECKING THE LOOP DETECTORS AND LOOP WIRES .....	94
23.5 CHECK SAFETY SIGNAGE .....	94
23.6 MAINTENANCE SERVICE RECORD .....	95
24. SPARE PARTS .....	96

## 1.0 Safety

### 1.1 Safety symbols used in this handbook

The following symbols are used in this operating instruction to indicate potential risks and other safety information.



**Warning!**

This symbol is used in this manual to warn installer for potential harm. Please read these instructions very carefully.



**Caution!**

This symbol is used in this manual to designate those actions or states which represent a potential hazard to pedestrian, personal, property and equipment. Please read these instructions very carefully.



**Note!**

This symbol is used in this manual to designate useful information for the operator.

### 1.2 General safety information

The MAGSTOP barrier system has been designed built and tested using state-of-the-art technology and left our factory only after passing stringent safety and reliability criteria. Nevertheless, the barrier system can represent a risk to persons and property if it is not installed and operated correctly. These operating instructions must therefore be read in their entirety and all safety information contained therein must be complied with.

The manufacturer shall refuse to accept liability and shall withdraw warranty if this barrier system is used incorrectly or is used for a purpose for which it was not intended.

### 1.3 Intended use

**The MAGSTOP MIB 30/40 barriers are designed to control vehicular (see pictogram below) access and exits to car parks, car parking garages, access control applications and highways.**

The MAGTRONIC control units have been specially designed for controlling Magnetic barriers.

Any other use of these barrier systems is not permitted.

Modifications or changes to the barrier or to the control modules are prohibited.

Only original Magnetic spare parts and accessories shall be used.

### 1.4 Warning and safety signage

The Magnetic Automation Corp. MIB barriers come with two (2) safety-warning labels (see Figure 1 below) that must be applied to the barrier housing so it can easily be seen when a pedestrian, bicycle users, or motorized vehicle uses the lane. Magnetic Automation Corp. requires that you use universally identifiable pictograms in all entrance/exit lanes, roadways, post, and walls. It is strongly recommended to paint a "NO PEDESTRIAN" pictogram on the roadway immediately adjacent to the parking barrier gate.

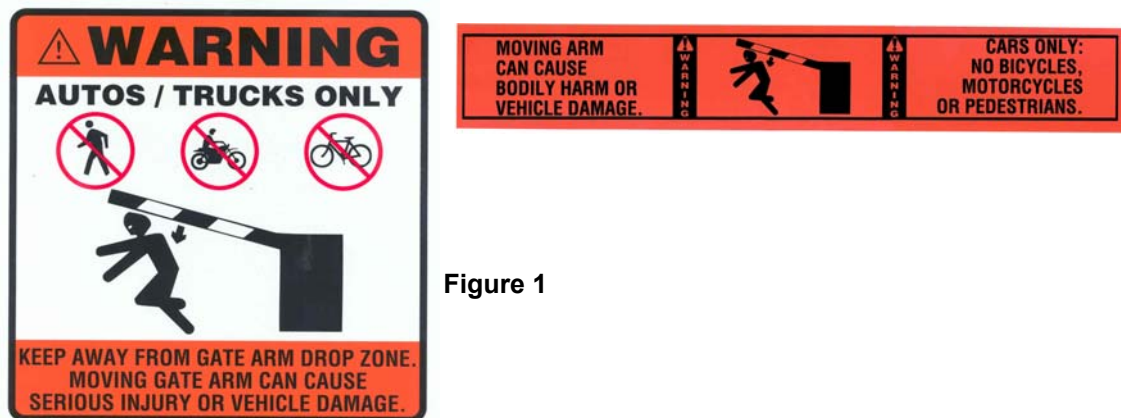

Figure 1

### 1.5 Safety Requirements



- Use vibrant colors on parking equipment
- Always provide proper signage, both on the road way and on other equipment
- Maintain manufacturers warning stickers on gate housing and gate arms.
- Always require that sidewalks are parallel to entrance and exit lanes, or require having pedestrian entrances on opposite side of vehicle entrance and exit.

**IMPORTANT:**

It is A MUST to have pedestrian sidewalks installed parallel to entrance and exit lanes or to have pedestrian walkways on the opposite sides of the facility away of vehicle traffic. It is also necessary to enforce that pedestrian are using those walkways and do not enter or leave the parking facility on vehicle traffic lanes.

**NOTE: NONE COMPLIANCE WITH THE ABOVE SAFETY REQUIREMENTS (Chapter 1.3 and 1.4) SHALL VOID ANY MANUFACTURERS LIABILITY!**

## 1.6 Operational safety

A safe clearance distance of at least 2 ft (24 inch) must be provided between the tip of the barrier boom and the closest solid obstacle (building, wall, fence etc.).

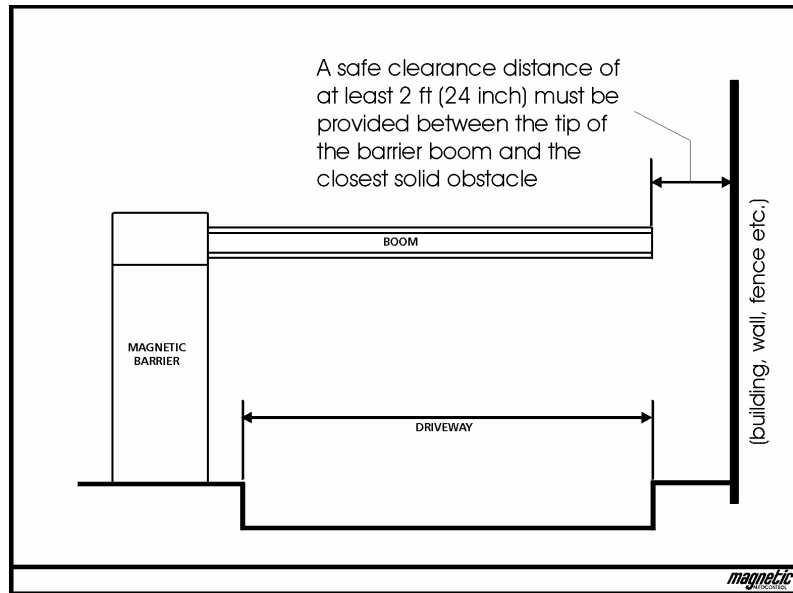

Any activity in the entrance and exit lanes should be monitored to ensure a safe operation when opening or closing the barrier gates or to prevent altering or vandalism to the equipment from unauthorized persons.

The motion of the barrier boom must be directly observable by the person operating the barrier.

While the barrier boom is in motion, no pedestrian and no vehicle shall be in the immediate vicinity of the barrier.

The assembly and installation instructions must be complied with in their entirety. Any alterations must have received prior confirmation from Magnetic Automation Corp.

Barrier booms longer than 14 ft require either a pendulum support or a supporting pillar.

Only certified and trained electrical technicians may perform any electrical connections, wiring work or exchange of components.

Before installing or maintaining, the equipment the main power must be disconnected.



### 1.7 Technical developments

The manufacturer reserves the right to modify, without prior notice, the technical specifications in order to accommodate the latest technical developments. Magnetic Automation Corp. will provide information on the status of existing operating instructions and on any alterations and extensions that may be relevant.

### 1.8 Warranty

Magnetic provides a limited warranty on its barriers that covers all mechanical and electrical components, but excludes parts subject to wear and tear, for a period of two years from the date of first use or for a maximum of three years from the date on which the system was delivered provided that the operating instructions have been complied with, no unauthorized servicing of machine components has taken place, and that no mechanical damage to the machines is evident.

Please refer to our Warranty Statement.

#### COPYRIGHT

© 2001 Magnetic Automation Corp.  
All rights reserved. No part of this publication may be reproduced, transmitted, transcribed, stored in a retrieval system, or translated into any language in any form by any means without the written permission of Magnetic Automation Corp.

First Printing: 2001

## 2.0 Installation

### 2.1 Guidelines for Foundation

To ensure that the equipment is installed solid to the ground under all operation conditions, a foundation with the following dimensions shall be provided:

Depth of foundation: at least 3ft (frost-depth)  
 Base area of foundation: 19" x 23 1/2"

The base of the foundation is 4" wider towards the vehicle passage side, than in other section of the foundation (see Fig. S0225).

Fig. S0225  
View of the foundation

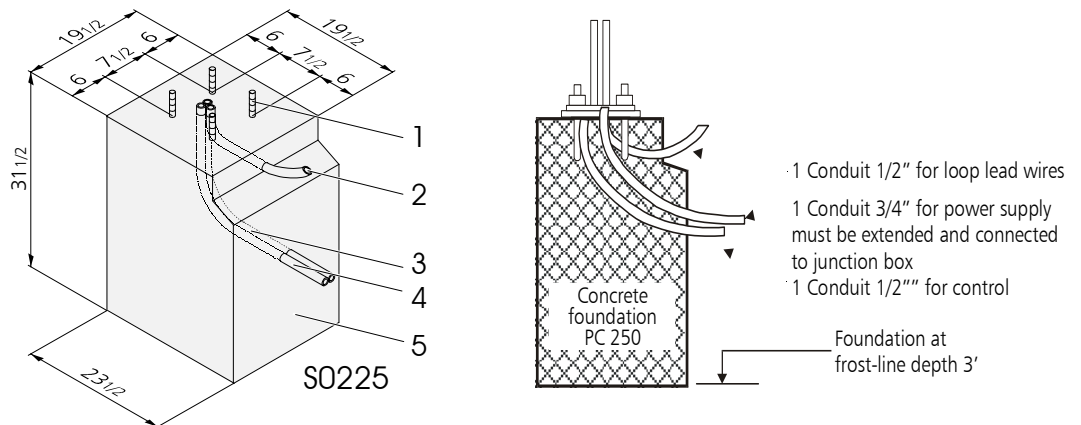

- 1 Anchor bolts (4x)
- 2 Empty conduit for induction loop lead wire, dia. 1/2"
- 3 Conduit for power cables, dia. 1"
- 4 Conduit for control cables, dia. 1/2"
- 5 Concrete foundation

Conduit pipes (with different diameters for low and high voltage cables as per Electrical code) must be installed to run the mains supply cable, the control cables and the induction loop lead-wires.

A reinforcing steel cage is essential for the stability of the foundation (see Fig. S0102).

Abb. S0102

Steel reinforcement for  
The concrete foundation

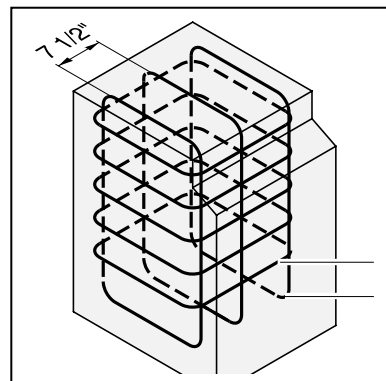

5 x  $\varnothing$  3/8" / 17 1/2" x 17 1/2" St III  
 3 x  $\varnothing$  1/2" / 29" x 16" St III

The foundation shall be constructed with at least 2500 PSI grade concrete. The mounting surface must be leveled to insure a solid base for the barrier gate. Once the concrete has set to an adequate hardness, the holes for the anchor bolts can be drilled using the dimensions shown in Fig. S0111 as a guide. Magnetic Automation Corp. recommends using  $\varnothing 3/8"$  anchor bolts. Please refer to the anchor bolt manufacturers installation requirements.

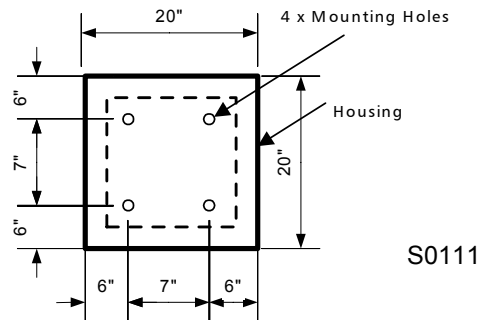

### 2.1 Mounting the housing to the ground

To mount the barrier gate on the concrete surface, follow the instructions below.

1. Carefully remove the gate from its shipping crate.
2. Open the barrier door
3. Place the gate on the desired position on the curb but leave 6"-12" distance from the front of the housing to the curb line.
4. Place the gate so that the gate arm flange faces the opposite direction of traffic. Please refer to the figure S0112 and compare the Packing list to assure the correct flange position (example: MIB30R-C100 = RH, MIB30L-C100 = LH).

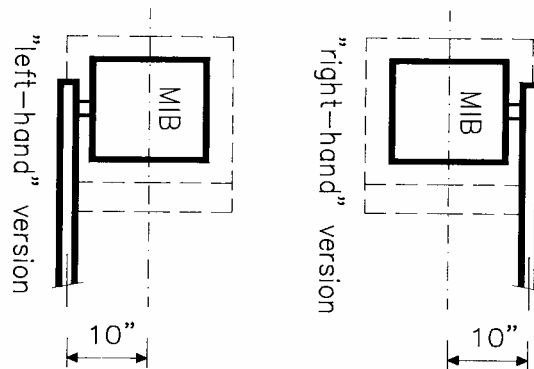

◀ road ▶

5. Using a marker, follow the outside and inside contours to the concrete.
6. Remove barrier gate.

- Using a pencil, mark the location of the mounting holes on the concrete. (See fig. S0111 for dimensions).

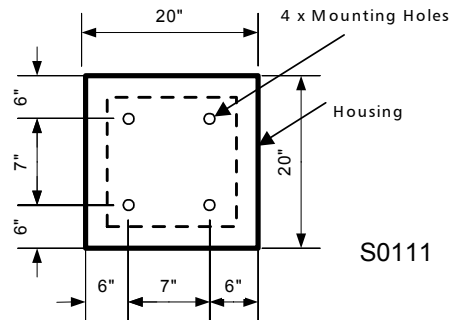

- Drill all four mounting holes and insert the bolts. (Please refer to anchor bolt manufacturers installation specifications). Make sure that the bolts stand up at least 2 inches above the concrete surface.
- Place the gate on top of the previous marked area.
- Using the supplied U-channel (in accessory box) secure the gate to the concrete (see Fig. S0106).

*Abb, S0106  
Mounting the barrier housing to the foundation*

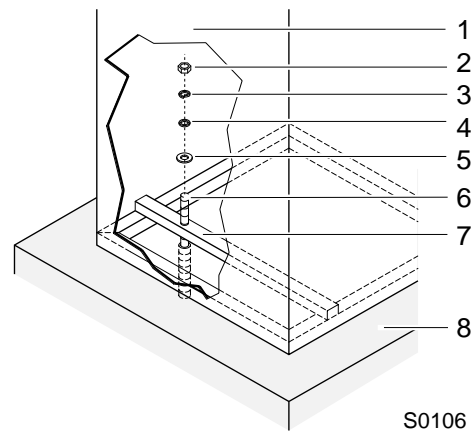

- barrier housing
- nut
- lock washer
- small flat washer
- large flat washer
- anchor bolt
- U-rail
- concrete foundation

- Attach the field wiring to the proper terminals at the main power board. See Drawing S0113 below. Make certain that the main circuit breaker is switched OFF. Connect all electrical wiring exactly as directed in the Connection Diagram.



Fig ▶ S0113  
Field wiring diagram

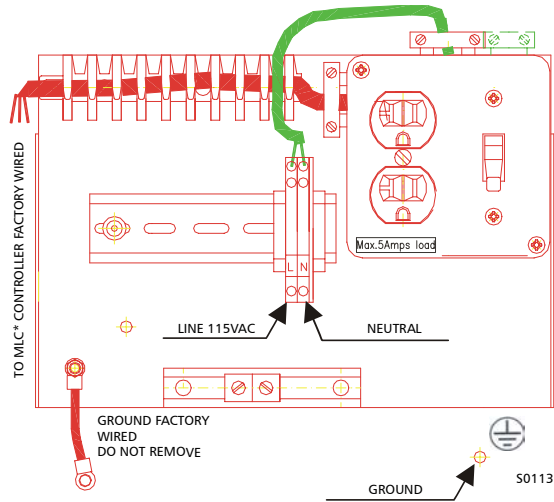

- Secure the boom flange (in accessory box) to the drive shaft using the using two M10 mm x 25mm hexagon socket screws. See Drawing below.

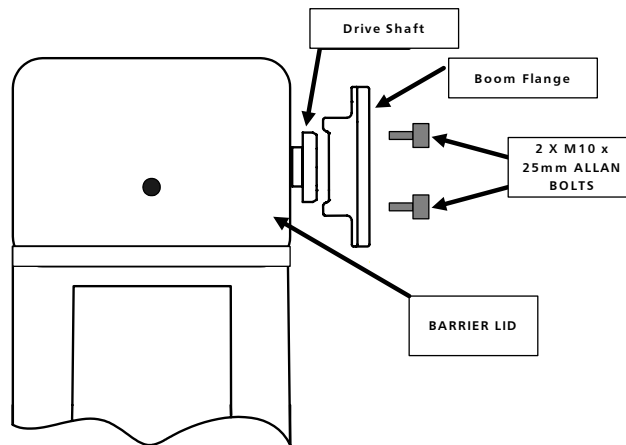

- Attach the boom arm to the flange using the boom attachment kit (in accessory box). Please refer to drawing below.

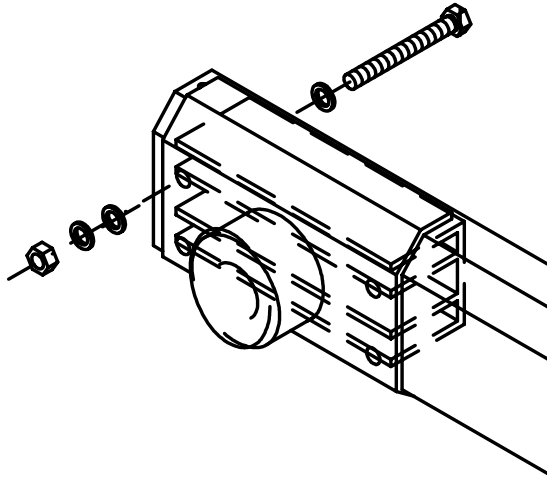

**Notice:**

With all MIB30 barriers, 8mm Nylon hex nuts are provided to mount the boom arm to the flange. This break away feature is only available for boom arms up to 12 ft. For barrier arm length, exceeding 12 ft it is not recommended to use any material other than the provided 8mm steel hex nuts. Due to age deterioration (UV radiation), the plastic nuts must be replaced annually.

### 3.0 Operating the MIB\* Barrier Gate

In automatic operation, the MIB\* Barrier gate can be operated using following devices:

- Ticket Spitters
- Vehicle Detectors
- Card Readers
- Coin and Token acceptors
- Radio Controllers
- Switches, Push buttons, and other devices.

## 4.0 MLC Controller

### Warning!

The following description is based on the standard parameter S 24008. Other parameters sets are not described in this manual.

### 4.1 General

The MLC control unit (Magnetic Lane Controller) has been specially designed for use with MIB 30/40 barrier gates.

All standard configurations can be achieved with this new generation controller. Via a potentiometer (boom position sensor), located at the motor drive shaft, the position of the barrier arm is continuously detected and the MLC controller evaluates the information.

This replaces the limit switch that is used in conventional barrier control systems. The combination of the potentiometer and the MLC unit guarantees the best possible control of the barrier boom movement.

The controller also has a 16-digit LCD display that shows the current settings and in/out -put stages at any time.

Software modifications are usually installed ex factory, however software upgrades can also be made during installation or thereafter via a software memory card and the interface connector.

The barrier is factory wired and supplied ready for immediate connection.

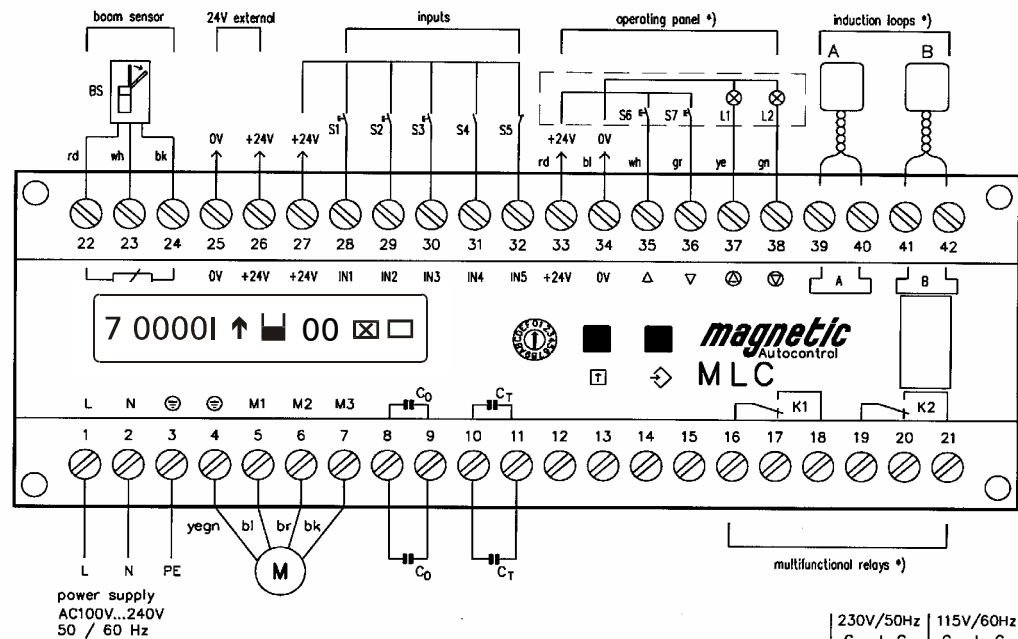

power supply  
AC100V...240V  
50 / 60 Hz

	230V/50Hz		115V/60Hz	
	C <sub>0</sub>	C <sub>T</sub>	C <sub>0</sub>	C <sub>T</sub>
MIB20	10µF	6µF	20µF	16µF
MIB30	3µF	3µF	10µF	8µF
MIB40	3µF	3µF	10µF	8µF

- BS boom sensor
- S1 open1 \*)
- S2 open2 (overriding) \*)
- S3 close \*)
- S4 external opening loop
- S5 external safety device
- S6 open/operating panel \*)
- S7 close/operating panel \*)
- L1 display open/operating panel \*)
- L2 display close/operating panel \*)
- A loop A \*)
- B loop B \*)
- M motor connections
- C<sub>0</sub> operating capacitor
- C<sub>T</sub> torque capacitor
- K1 multifunctional relay1 \*) (currentless)
- K2 multifunctional relay2 \*) (currentless)

\*) function as per adjusted mode, see operating instructions.

### 4.1 MLC Controller Setup

Abb.S0227  
MLC control panel

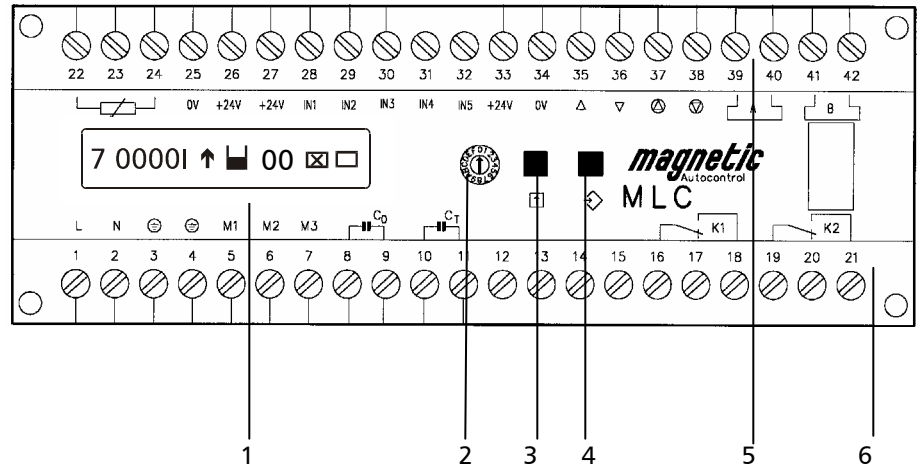

- 1 16- digit liquid crystal display (LCD) for indicating operational and programmed data
2. Rotary selector switch to select operating and setup modes
3. Black button open/scroll/save (operating mode/programming mode)
4. White button close/enter (operating mode/programming mode)
5. Terminal strip – control voltage side
6. Terminal strip – Motor and relay output



**NOTE:**

**THE MLC\* CONTROLLER HAS UNIVERSAL MAIN VOLTAGE INPUT (85-V-265V) BUT THE MOTOR DOES NOT. PLEASE CHECK THE SERIAL NUMBER LABEL FOR THE BARRIER FOR INPUT VOLTAGE.**



### 4.2 Display information

Normal operating mode, rotary switch set to '0'. Following information is displayed:

**Note:**

**IN5 (external safety input) must be made (activated) in order for the barrier gate to operate. Standard factory setup is a jumper wire to activate this input and using the internal Loop A as safety device.**



Abb.S0228  
Display information

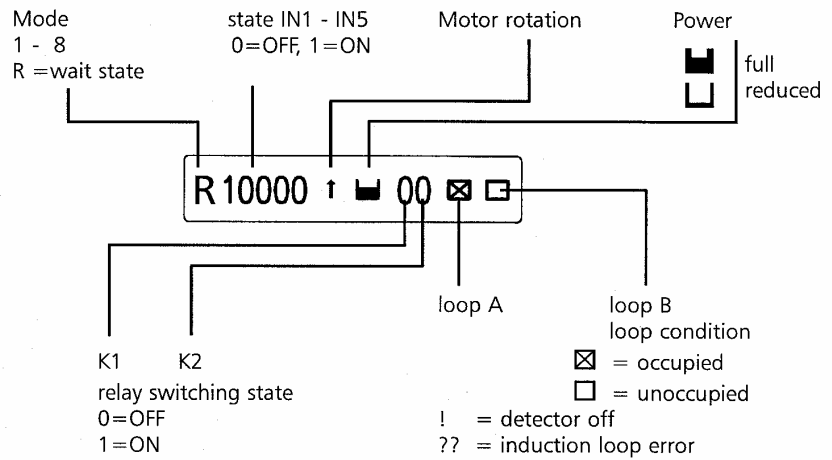

### 4.3 Programming and reading the operating data

Abb. S0230

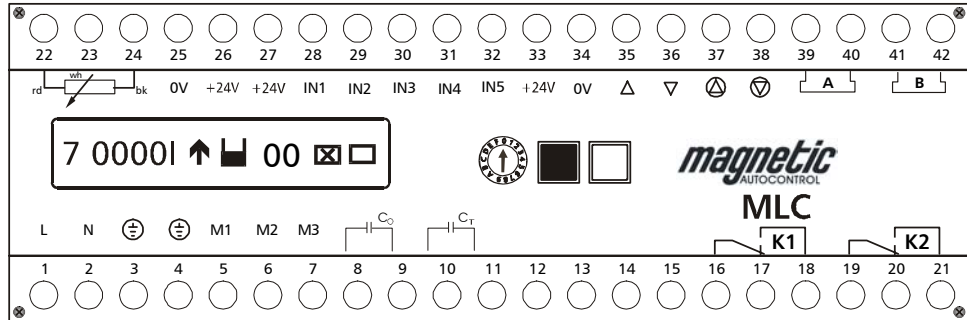

#### General operating data:

Rotary Switch Position 0: Barrier operating mode	
Rotary Switch Position 1: program number .....	1 - 8
Rotary Switch Position 2: torque time .....	1 - 30 sec.
Rotary Switch Position 3: barrier-open period .....	1 - 255 sec.
Rotary Switch Position 4: Sensitivity induction loop A .....	0 - 9 (0=min., 9=max.)
Rotary Switch Position 5: Sensitivity induction loop B .....	0 - 9 (0=min., 9=max.)
Position 6: detector mode A .....	0 - 9 (see table for description)
Position 7: detector mode B .....	0 - 8 (see table for function description)
Position 8: frequency of induction loops A/B .....	10,000 Hz - 90,000 Hz
Position 9: spare	
Position A: spare	
Position B: spare	
Position C: spare	
Position D: hardware error controller .....	hexadecimal error code
Position E: language .....	German, English, French, Spanish
Position F: factory settings .....	resets all operating data to default settings

### 4.3.1.1 Programming modes short description

(Selector switch position '1' see chapter 5.0 for detailed description):

Program number	Function:
1	Barrier controlled by a potential-free switch
2	Dead man function
3	Barrier controlled by pulses from a single push button
4	Barrier controlled by pulses from two separate push buttons
5	Automatic with barrier-hold open timer
6	Automatic with barrier-hold open timer, opening loop disabled when vehicle passes from opposite direction
7	Automatic without barrier-hold open timer
8	Automatic without barrier-hold open timer, opening loop disabled when vehicle passes from opposite direction

### 4.3.1.2 Short description of the general operating data:

Torque time: Pos.2	Period for which the barrier motor has full torque, when time elapses controller switches to low power consumption.
Barrier-hold open timer Pos.3:	Time after which the barrier closes automatically if no vehicle has passed through the safety device.
Loop sensitivity Loop A Pos. 4 Loop B Pos. 5	Inductive loop Sensitivity level A = safety/closing loop, B = opening / presence loop
Detector mode Loop A Pos. 6 Loop B Pos. 7	Function of the loop detectors A/B and the relays K1/K2. See Section 6.5: 'Adjusting the induction loops'.
Detector frequency Pos. 8	Displays current frequency for loop A and loop B See Chapter 9.0 for more details.
K1 relay output Pos. B	This setting is only functioning when Mode Loop a = 0 (disabled). The position when Relay K1 should switch can be adjusted.
Hardware error Pos. D	Hexadecimal error code, only relevant for manufacturer's own error detection procedures
Language Pos. E	Language selection for LCD messages (German, English, French, Spanish)
Factory settings Pos. F	Resets the operating data to the original default settings. Caution! Use only in exceptional circumstances!

## 5.0 Programming Modes

1.0 To select a Programming mode turn the rotary switch in position 1.

Display Message:

program number X

X = Current Program mode number

2.0 To change to different Program Mode press and hold both, the black and the white button down. A cursor will appear below the number. Release both buttons.

3.0 When cursor appeared below the number use the black button to scroll through the available program modes.

4.0 When desired mode appeared on display press the white button.

Display Message:

Save Y=↑ N=↓ ?

5.0 In order to save your changes press the Black button

Display Message:

program number X

X = Selected Program mode number

6.0 To return to the normal operating mode turn rotary switch to Position 1

### 5.1 Available Program Modes and functions

**Important note:** The information provided here is based on the standard program S24008. Differences may exist to other standard programs or customized versions. These programs are documented and attached to this standard manual as addendum.

To find out what software is currently installed please read chapter 17.1. All external equipment that uses the MLC\* controller inputs (e.g. push buttons, light barriers, limit switches) must be connected as potential free contacts. Contact Magnetic for advice before connecting any equipment that does not meet those requirements.



**Note:**

**DO NOT CONNECT ANY DEVICE WHICH WOULD DELIVER ANY VOLTAGE OF ANY KIND TO THE INPUTS OF THE MLC\* CONTROLLER.**

**Note:**

**External safety devices other than the internal loop A of the MLC\* controller must be connected as normally closed contact to IN 5 (Terminal 32) and terminal 33 (+24VDC).**

**If the internal loop A is used as safety device no additional wiring is necessary but a jumper wire between IN5 (terminal 32) and terminal 33 (+24VDC) is imperative. This jumper wire is installed ex factory and loop A is defaulted as safety device.**

**Following are the functional descriptions of the available Program Modes**

### 5.1.1 Program 1 (Mode 1):

(Maintained contact)

A potential free switch controls the barrier.

Contact closed = barrier closed. Contact open = barrier open.

**Internal Loop A (safety loop) will not close the gate. Loop B can only operated as presence loop.**

#### Connections:

IN1 Terminal 27 and 28 = no function

IN2 Terminal 27 and 29 = no function

IN3 Terminal 27 and 30 = Contact closed=gate closed, Contact open=gate open.

IN4 Terminal 27 and 31 = no function

IN5 Terminal 32 and 33 = External Safety device (Normally closed contact). The safety device will not close the gate. Loop B can only be operated as presence loop.

#### Wiring Diagram:

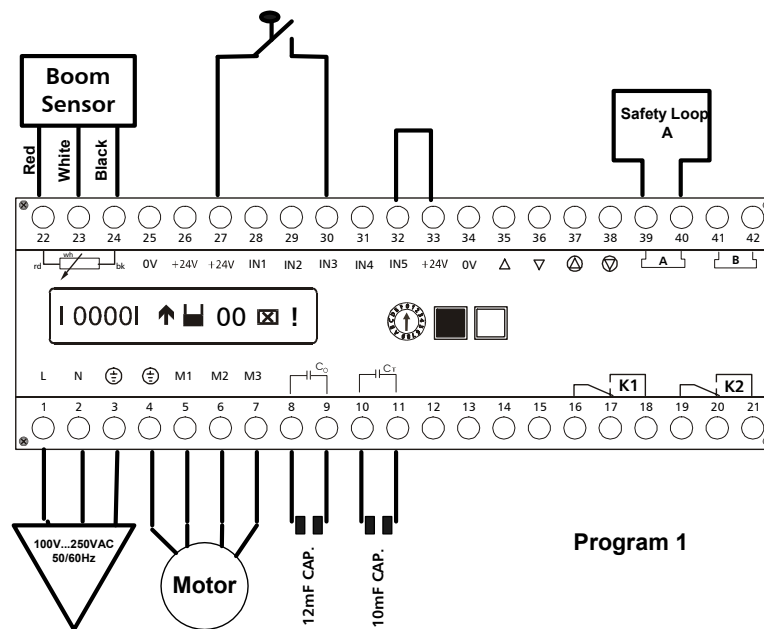

#### Note:

This program mode is mostly used when only one switch is available and a guard, who is in the vicinity of the barrier, operates the gate.

When using other safety devices then the internal safety Loop A connect it to IN5 on terminal 32 and 33. The external safety device must use a NC contact and the existing jumper wire must be removed. When no external safety device is used, a jumper wire on IN 5 (wired ex factory) is necessary to operate the gate.

**All inputs must be potential free (dry contacts) contacts.**

### 5.1.2 Program 2 (Mode 2):

Dead-man (Pulse to open, maintain contact to close). The gate closing input must be activated (made) until the arm reaches the full down position.

**Internal Loop A (safety loop) or the external safety device (IN5) will not close the gate. Loop B can only operated as presence loop.**

**Connections:**

IN1 Terminal 27 and 28 = Momentary Signal (pulse) to open the gate.

IN2 Terminal 27 and 29 = no function

IN3 Terminal 27 and 30 = Maintained Contact to close the gate

IN4 Terminal 27 and 31 = no function

IN5 Terminal 32 and 33 = External Safety device (Normally closed contact).

**Wiring Diagram:**

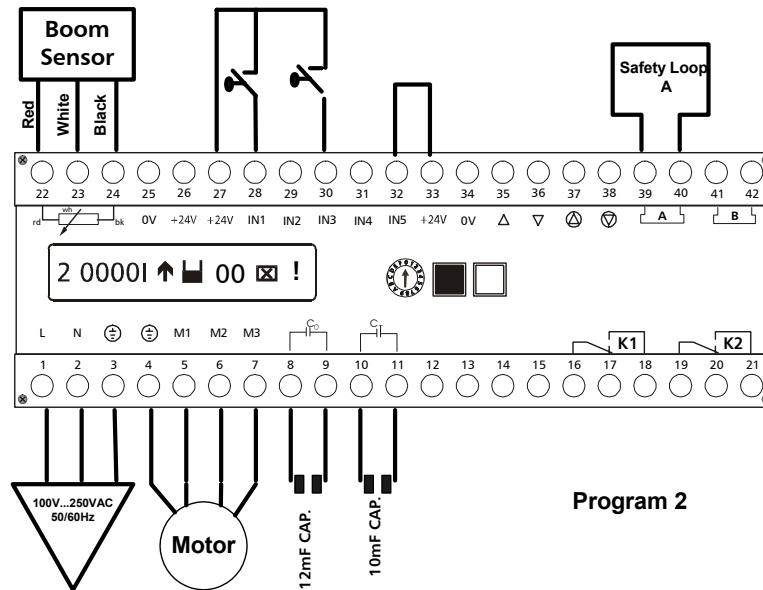

Program 2

**Note:**

This program mode is mostly used when a guard who is in the vicinity of the barrier guards the entrance or exit.

When using other safety devices then the internal safety Loop A connect it to IN5 on terminal 32 and 33. The external safety device must use a NC contact and the existing jumper wire must be removed. When no external safety device is used, a jumper wire on IN 5 (wired ex factory) is necessary to operate the gate.

**All inputs must be potential free (dry contacts) contacts.**

### 5.1.3 Program 3 (Mode 3):

Pulse control

Each pulse (input) results in a change of travel direction (up/down) of the barrier arm.  
1st pulse: barrier opens, 2nd pulse: barrier closes, 3rd pulse: barrier opens, ... etc.

**Internal Loop A (safety loop) or the external safety device (IN5) will not close the gate. Loop B can only be operated as the presence loop.**

#### Connections:

- IN1 Terminal 27 and 28 = Momentary Signal 1st pulse: barrier opens, 2nd pulse: barrier closes, 3rd pulse: barrier opens ... etc.
- IN2 Terminal 27 and 29 = no function
- IN2 Terminal 27 and 29 = no function
- IN3 Terminal 27 and 30 = no function
- IN4 Terminal 27 and 31 = no function
- IN5 Terminal 32 and 33 = External Safety device (Normally closed contact)

#### Wiring Diagram:

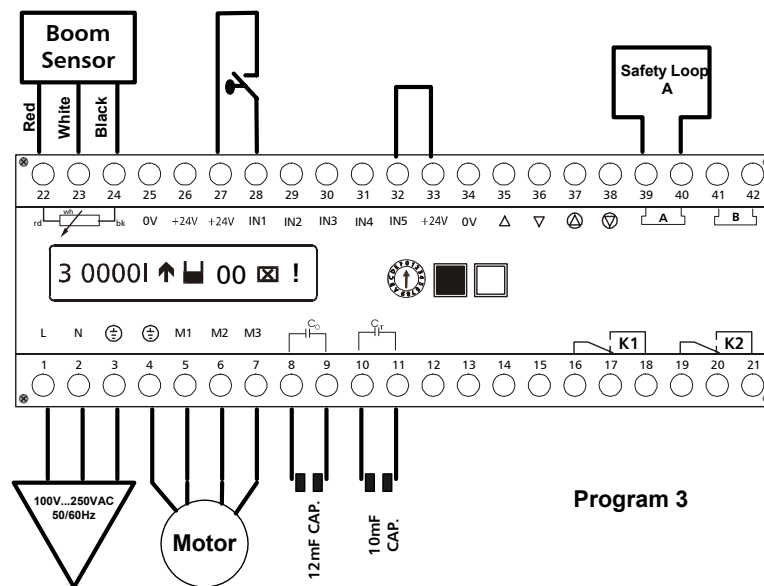

#### Note:

This program mode is mostly used when a guard who is in the vicinity of the barrier guards the entrance or exit.

When using other safety devices then the internal safety Loop A connect it to IN5 on terminal 32 and 33. The external safety device must use a NC contact and the existing jumper wire must be removed. When no external safety device is used, a jumper wire on IN 5 (wired ex factory) is necessary to operate the gate.

**All inputs must be potential free (dry contacts) contacts.**



### 5.1.4 Program 4 (Mode 4):

Pulses from two different normally open devices control the barrier position.

**Internal Loop A (safety loop) or the external safety device (IN5) will not close the gate. Loop B can only operated as presence loop.**

#### Connections:

IN1 Terminal 27 and 28 = Momentary Signal gate open

IN2 Terminal 27 and 29 = Override gate open (highest priority)

IN3 Terminal 27 and 30 = Momentary Signal gate close

IN4 Terminal 27 and 31 = no function

IN5 Terminal 32 and 33 = External Safety device (Normally closed contact)

#### Wiring Diagram:

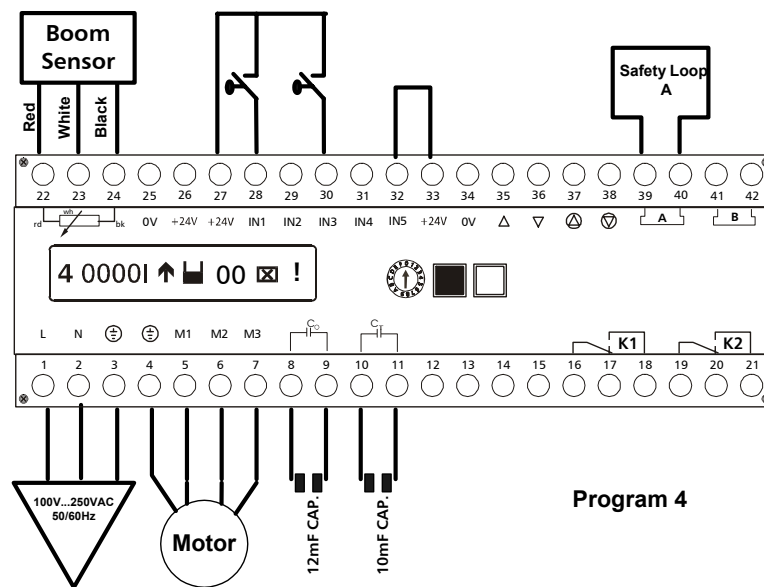

#### Note:

This program mode is used mostly on toll road applications where lane controllers control the gate and no automatic functioning is required.

When using other safety devices then the internal safety Loop A connect it to IN5 on terminal 32 and 33. The external safety device must use a NC contact and the existing jumper wire must be removed. When no external safety device is used, a jumper wire on IN 5 (wired ex factory) is necessary to operate the gate.

**Inputs on IN2 will override all existing closing inputs.**

**All inputs must be potential free (dry contacts) contacts..**



### 5.1.5 Program 5 (Mode 5):

Automatic Mode.

The barrier is opened by a pulse and/or opening loop and closes automatically after an adjustable time, or immediately after the safety device (Loop A or external IN5) has been passed or a closing input on IN3 has been given.

#### Connections:

IN1 Terminal 27 and 28 = Momentary Signal gate open

IN2 Terminal 27 and 29 = Override gate open (highest priority)

IN3 Terminal 27 and 30 = Momentary Signal gate close

IN4 Terminal 27 and 31 = no function

IN5 Terminal 32 and 33 = External Safety and gate Closing device (Normally closed contact).

#### Wiring Diagram:

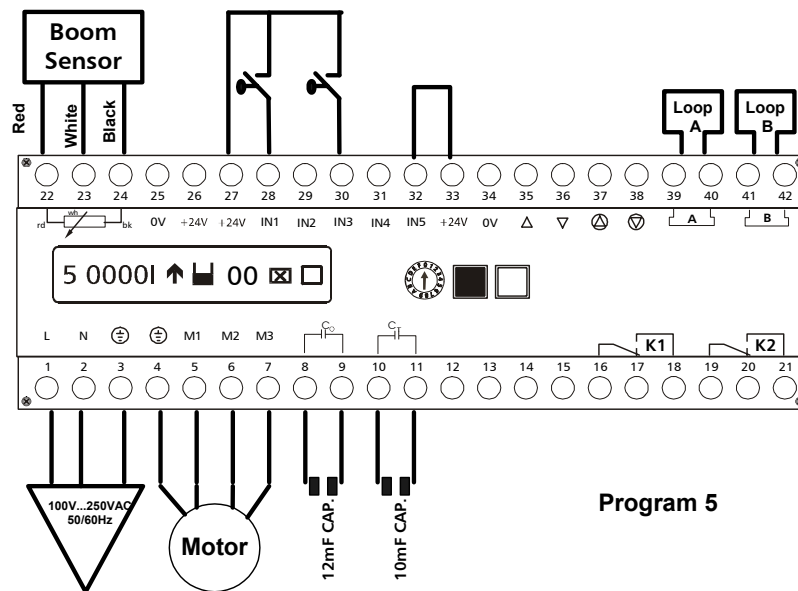

#### Note:

This program mode is used when automatic functioning of the gate is required. The gate receives an opening command and closes when the vehicle passes through the safety/closing loop after the adjustable hold-open time expires or when a closing input on IN3 was made.

When using other safety devices then the internal safety Loop A connect it to IN5 on terminal 32 and 33. The external safety device must use a NC contact and the existing jumper wire must be removed. When no external safety device is used, a jumper wire on IN 5 (wired ex factory) is necessary to operate the gate.

**Inputs on IN2 will override all existing closing inputs.**

**All inputs must be potential free (dry contacts) contacts**

If Loop A is activated and loop B configured as opening loop the gate closes after the vehicle passed **both** loops, **not** immediately after leaving the safety loop.  
Logic: Loop A, AB,B, gate closes. See drawings below.

### 1.0 Gate closed, patron opens gate.

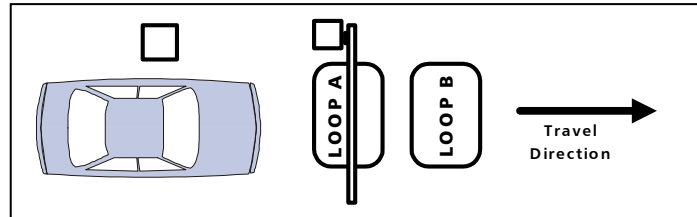

### 2.0 Gate opens and vehicle passes through Loop A, gate still in Position.

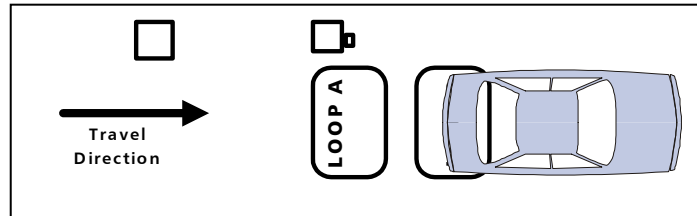

### 3.0 Vehicle leaves Loop B and gate closes.

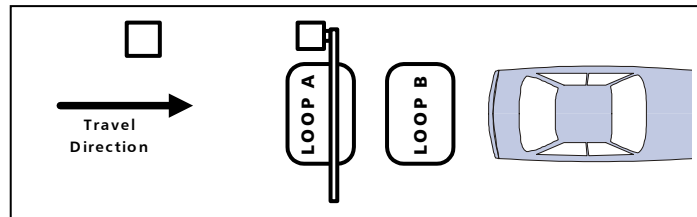

### 5.1.6 Program 6 (Mode 6):

This program works essentially the same way as Program 5 but has directional loop logic in addition to the Program 5 features. The difference is that in Program 5 the barrier closes automatically after a vehicle has completely passed over the safety and opening loops. In Program 6, the barrier closes immediately after the vehicle has crossed the safety loop. The opening loop has, at this time, no effect as long the safety-closing loop is triggered first.

#### Connections:

IN1 Terminal 27 and 28 = Momentary Signal gate open

IN2 Terminal 27 and 29 = Override gate open (highest priority)

IN3 Terminal 27 and 30 = Momentary Signal gate close

IN4 Terminal 27 and 31 = no function

IN5 Terminal 32 and 33 = External Safety and gate Closing device (Normally closed contact.)

#### Wiring Diagram:

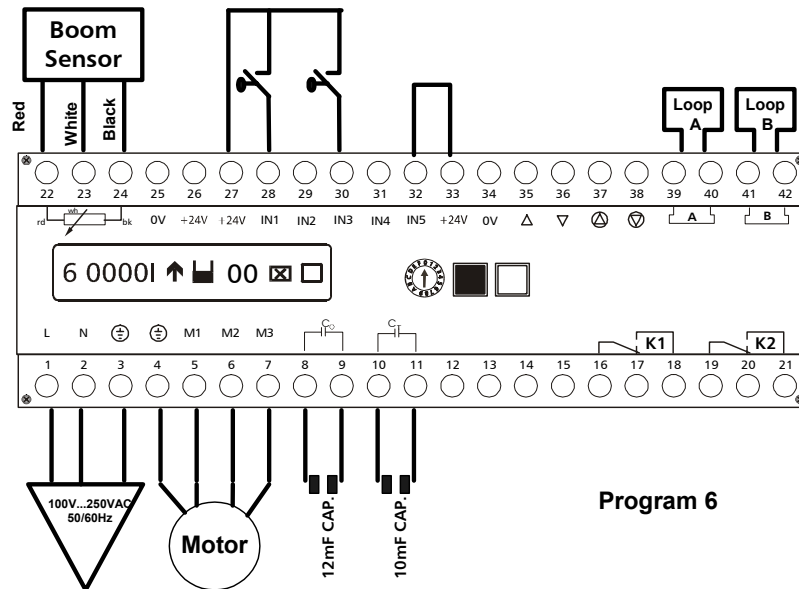

#### Note:

This program mode is used when automatic functioning of the gate is required. The gate receives an opening command and closes when the vehicle passes through the safety/closing loop after the adjustable hold-open time expires or when a closing input at IN3 was made.

When using other safety devices then the internal safety Loop A connect it to IN5 on terminal 32 and 33. The external safety device must use a NC contact and the



existing jumper wire must be removed. When no external safety device is used, a jumper wire on IN 5 (wired ex factory) is necessary to operate the gate.

**Inputs on IN2 will override all existing closing inputs.**

**All inputs must be potential free (dry contacts) contacts**

If Loop A is activated and loop B configured as opening loop the gate closes after the vehicle passed Loop A

Logic: Loop A, AB,B gate closes. See drawings below.

### 1.0 Gate closed, patron opens gate.

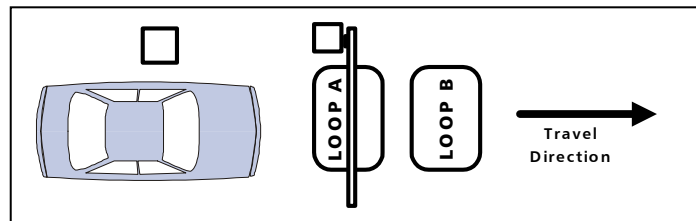

### 2.0 Gate opens and vehicle passes through Loop A, gate closes.

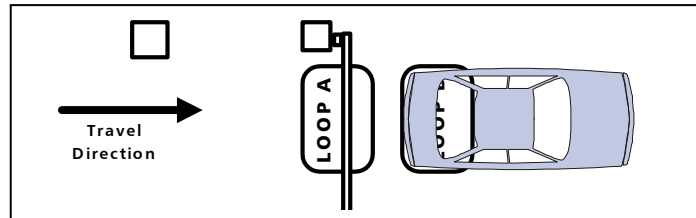

### 3.0 Vehicle leaves Loop B and gate remains closed.

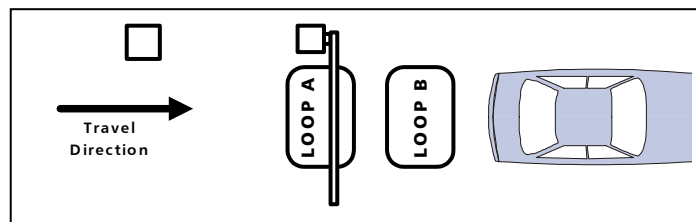

### 5.1.7 Program 7 (Mode 7):

Like mode 5 but without automatic time-out to close. The barrier remains open until a vehicle has activated the safety device and only closes after it has left the detection area or a closing command was given.

**Connections:**

- IN1 Terminal 27 and 28 = Momentary Signal gate open
- IN2 Terminal 27 and 29 = Override gate open (highest priority)
- IN3 Terminal 27 and 30 = Momentary Signal gate close
- IN4 Terminal 27 and 31 = no function
- IN5 Terminal 32 and 33 = External Safety and gate Closing device (Normally closed contact.)

**Wiring Diagram:**

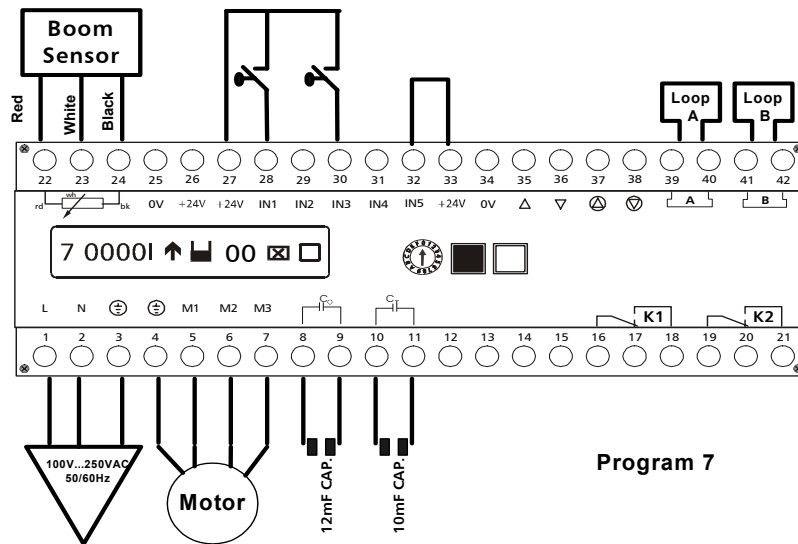

**Note:**

This program mode is used when the gate is used in parking applications where the barrier is controlled by an entry or exit station and no hold-open timer is required. The gate will only close when a vehicle passed through the safety/closing loop or a closing pulse was given (for example: Back out timer).

When using other safety devices then the internal safety Loop A connect it to IN5 on terminal 32 and 33. The external safety device must use a NC contact and the existing jumper wire must be removed. When no external safety device is used, a jumper wire on IN 5 (wired ex factory) is necessary to operate the gate.

**Inputs on IN2 will override all existing closing inputs.  
All inputs must be potential free (dry contacts) contacts**



### 5.1.8 Program 8 (Mode 8):

Like mode 6 but without automatic time out to close. The barrier remains open until a vehicle has activated the safety device and only closes after it has left the detection area or a closing command was given.

**Connections:**

- IN1 Terminal 27 and 28 = Momentary Signal gate open
- IN2 Terminal 27 and 29 = Override gate open (highest priority)
- IN3 Terminal 27 and 30 = Momentary Signal gate close
- IN4 Terminal 27 and 31 = no function
- IN5 Terminal 32 and 33 = External Safety and gate Closing device (Normally closed contact.)

**Wiring Diagram:**

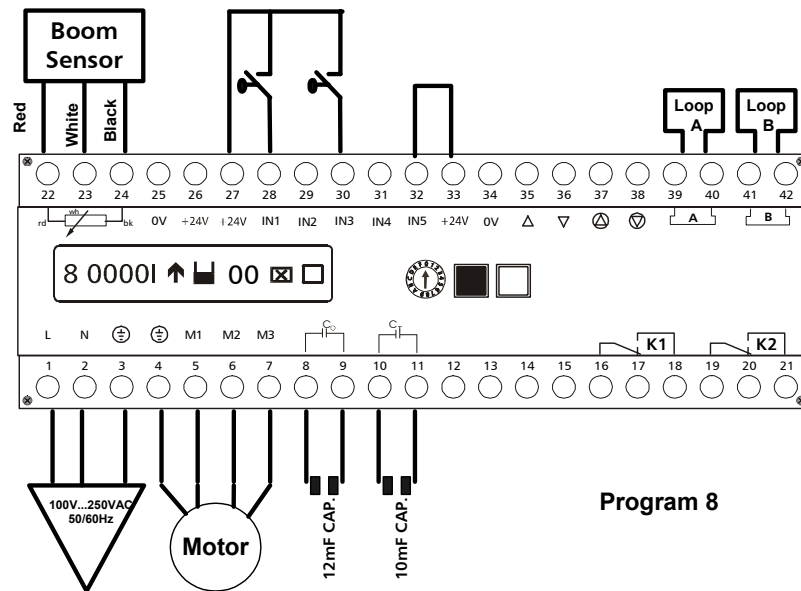

**Note:**

This program mode is used when automatic functioning of the gate is required. The gate receives an opening command and closes when the vehicle passes through the safety/closing loop after the adjustable hold-open time expires or when a closing input at IN3 was made.

When using other safety devices then the internal safety Loop A connect it to IN5 on terminal 32 and 33. The external safety device must use a NC contact and the existing jumper wire must be removed. When no external safety device is used, a jumper wire on IN 5 (wired ex factory) is necessary to operate the gate.

**Inputs on IN2 will override all existing closing inputs.  
All inputs must be potential free (dry contacts) contacts**



## 6.0 Torque time settings

During the arm movement, the motor runs with full torque (i.e. 115VAC). After reaching the end positions, the MLC controller switches the motor to a low power consumption mode. The time in which the motor runs in full torque can be adjusted using the torque time menu at rotary switch position 2. This can be necessary when the barrier is installed in heavy wind areas or extreme cold climates. Ex factory, the torque time is adjusted using the pre-programmed settings of the MLC controller software.

The torque time is adjustable from 1-30 seconds.

### 6.1 How to adjust the torque time:

1.0 To change the torque timer turn the rotary switch to position 2.

Display Message:

Torque time XX

XX = Current torque time setting

2.0 To change the torque time press and hold the black and the white button down. A cursor will appear below the first number. Release both buttons. To change this number press the black button, to switch to the second number press the white button.

3.0 When desired time is adjusted press the white button.

Display Message:

Save Y=↑ N=↓ ?

5.0 In order to save your changes press the Black button

Display Message:

Torque time XX

XX = Adjusted torque time setting.

6.0 To return to the normal operating mode turn rotary switch to Position 1



## 7.0 Hold Open timer

The “Hold open timer” is only effective in the automatic Programming modes 5 and 6. The barrier will close when this timer expires after a barrier opening command has been given but no vehicle has passed the safety/closing device within the adjusted time. Ex factory, the timer is adjusted to 35 seconds. The timer can be adjusted from 1-255 seconds.

### 7.1 How to adjust the hold open timer:

1.0 To change the hold open time, turn the rotary switch to position 3.

Display Message:

Hold-open t    XXX

XX = Current time setting

4.0 To change the hold open time press and hold both, the black and the white button down. A cursor will appear below the first number. Release both buttons. To change this number press the black button, to switch to the second or third number press the white button to change the numbers press the black button and the number increments by 1.

5.0 When desired time is adjusted press the white button.

Display Message:

Save Y=↑ N=↓    ?

5.0 In order to save your changes press the Black button

Display Message:

Hold-open t    XXX

XX = Adjusted hold open time.

6.0 To return to the normal operating mode turn the rotary switch to Position 1.

## 8.0 Loop Detector Sensitivity

Each individual internal loop detector has its own sensitivity adjustment. Rotary switch position 4 adjusts the sensitivity for Loop A and position 5 for Loop B.

It might be necessary to change the sensitivity of the loop if the loop at the individual installation requires it. Ex factory the loop sensitivity for Loop A and Loop B is adjusted to 5.

The sensitivity can be adjusted from 0-9 with the higher number being the highest sensitivity.

### 8.1 How to adjust the Loop A sensitivity:

1.0 To change the sensitivity for Loop A turn the rotary switch to position 4.

Display Message:

Sensitivity A    X

XX = Current sensitivity setting

2.0 To change the sensitivity press and hold both, the black and the white button down. A cursor will appear below the number. Release both buttons. To change the number press the black button, the number increments by 1.

3.0 When the desired number is displayed press the white button.

Display Message:

Save Y=↑ N=↓    ?

4.0 In order to save your changes press the Black button

Display Message:

Sensitivity A    X

XX = Adjusted sensitivity setting.

5.0 To return to the normal operating mode turn rotary switch to Position 1.

6.0 To adjust the Loop B sensitivity turn the rotary switch to Position 5 and follow above steps 1-5.

## 9.0 Configuring the loop detectors

The MLC controller used in all Magnetic MIB Barriers comes standard with two internal loop detectors.

Loop A and Loop B.

Each loop has one NO & NC relay output available. Both loop detectors and the relay can be configured using the programming menu.

### 9.1 Safety/Closing Loop A

Loop A (Terminal 39 and 40) is configured ex factory as safety/closing loop.

The output relays K1 are located on terminal 16 (Common), 17 (NC) and 18 (NO).

**To configure the loop detector and the relay function please follow these steps:**

1.0 Turn rotary switch in Position 6

Display Message:

Mode Loop A X

X = Current Program mode number

2.0 To change the Loop mode press and hold both, the black and the white button down. A cursor will appear below the number. Release both buttons.

3.0 When cursor appears below the number use the black button to scroll through the available program modes.

4.0 When desired mode appears on the display press the white button

Display Message:

Save Y=↑ N=↓ ?

5.0 In order to save your changes press the Black button

Display Message:

Mode Loop A X

X = Selected Loop mode number

6.0 To return to the normal operating mode turn rotary switch to Position 1

## 9.2 Loop A Mode function

### 9.2.1 Detector Mode A

Mode	Internal function	Function K1
0	Loop is disabled	Maintained contact when gate is full open
1	Safety / closes barrier (Program 5-8)	Maintained contact when gate is full open
2	Safety / closes barrier (Program 5-8)	Maintained contact when Loop A is occupied
3	Safety / closes barrier (Program 5-8)	Pulse signal when vehicle enters Loop A
4	Safety / closes barrier (Program 5-8)	Pulse signal when vehicle leaves Loop A
5	Safety / closes barrier (Program 5-8)	Pulse signal with directional logic (see below)
6	Safety / closes barrier (Program 5-8)	Pulse signal with directional logic (see below)
7	Safety / closes barrier (Program 5-8)	Maintained Signal with directional logic (see below)
8	Safety / closes barrier (Program 5-8)	Maintained Signal with directional logic (see below)
9	No safety/closing function	Maintained contact when Loop A is occupied

### 9.2.2 Directional Logic Loop A

In Loop Modes 5,6,7 and 8 the relays corresponding to Loop A and Loop B can be set to provide pulses or maintained contacts depending in what direction the vehicle travels.

Relay K1 (Terminal 16/17/18) respond to Loop A.

#### Loop A Mode 5

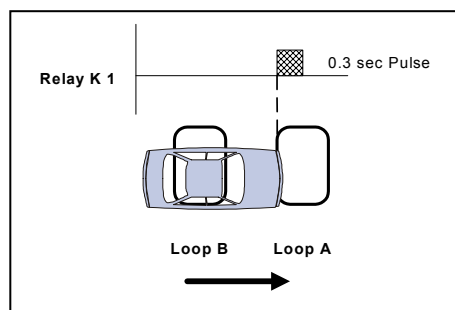

Vehicle travels from Loop B to Loop A. A 300mS pulse will be issued on relay K1 when vehicle drives on Loop B and then Loop A.

Logic:  
B/BA (pulse)



#### Note:

For the directional logic to function, Loop A and Loop B, it must be assured that the vehicles that use this lane trigger both loops at the same time. If this cannot be achieved a special input counting software is required. In this case, please call for further details.

**Loop A Mode 6**

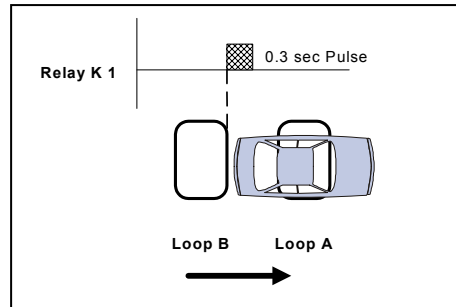

Vehicle travels from Loop B to Loop A. A 300mS pulse will be issued on relay K1 when vehicle drives on Loop B then loop A and then leaves Loop B while still on Loop A.  
Logic: B/BA/A (pulse)

**Note:**

For the directional logic to function, Loop A and Loop B, it must be assured that the vehicles that use this lane trigger both loops at the same time. If this cannot be achieved a special input counting software is required. In this case, please call for further details.



**Loop A Mode 7**

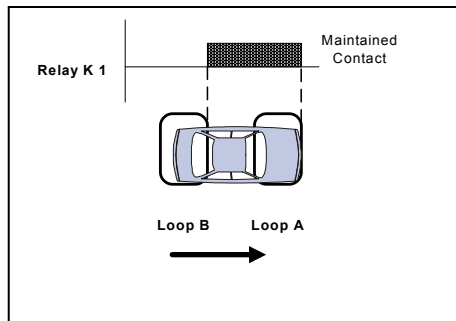

Vehicle travels from Loop B to Loop A. A maintained contact on relay K1 is made when vehicle drives from loop B to loop A until the vehicle leaves loop A.  
Logic: B/BA (Maintained contact)/A (Maintained contact)

**Note:**

For the directional logic to function, Loop A and Loop B, it must be assured that the vehicles that use this lane trigger both loops at the same time. If this cannot be achieved a special input counting software is required. In this case, please call for further details.



**Loop A Mode 8**

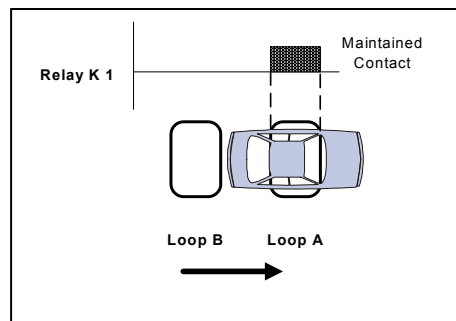

Vehicle travels from Loop B to Loop A. A maintained contact on relay K1 is made when the vehicle drives from loop B to loop A and leaves loop B while still on loop A.  
Logic: B/BA/A (Maintained contact)

**Note:**

For the directional logic to function, Loop A and Loop B, it must be assured that the vehicles that use this lane trigger both loops at the same time. If this cannot be achieved a special input counting software is required. In this case, please call for further details.



### 9.3 Opening or Presence Loop B

Loop B (Terminal 41 and 42) is configured ex factory as presence loop.  
The output relays K2 are located on terminal 19 (Common), 20 (NC) and 21 (NO).

To configure the loop detector and the relay function please follow these steps:

1.0 Turn rotary switch in Position 7

Display Message:

Mode Loop B X

X = Current Loop Mode number

- 2.0 To change the Loop mode press and hold both, the black and the white button down. A cursor will appear below the number. Release both buttons.
- 3.0 When cursor appears below the number, use the black button to scroll through the available program modes.
- 4.0 When desired mode appears on display press the white button

Display Message:

B Presence Loop

B Opening Loop

5.0 If this installation requires a presence contact (arming loop), select "B Presence Loop" if this installation requires a free entry, or exit setup select "B opening loop" by pressing the black button to toggle between the two options. To select the desired option press the white button.

Display Message:

B Entrance Loop

B Exit Loop

6.0 The menu now provides the option to select "B Entrance Loop" or "B Exit Loop". This option affects only software versions with differential counting. Please select if your gate is an exit or an entry lane. If you have traffic in both directions please select "Entrance Loop". To toggle between the two options press the black button and confirm your selection by pressing the white button.

Display Message:

Save Y=↑ N=↓ ?

7.0 In order to save your changes press the Black button

Display Message:

Mode Loop B    X

X = Selected Loop Mode number

8.0 To return to the normal operating mode turn rotary switch to Position 1

### 9.3.1 Detector mode B

Mode	Internal function	Function K2
0	Loop is disabled	Maintained contact when gate is full closed
1	Opening Loop (Program 5-8) or presence loop	Maintained contact when gate is full closed
2	Opening Loop (Program 5-8) or presence loop	Maintained contact when Loop B is occupied
3	Opening Loop (Program 5-8) or presence loop	Pulse signal when vehicle enters Loop B
4	Opening Loop (Program 5-8) or presence loop	Pulse signal when vehicle leaves Loop B
5	Opening Loop (Program 5-8) or presence loop	Pulse signal with directional logic (see below)
6	Opening Loop (Program 5-8) or presence loop	Pulse signal with directional logic (see below)
7	Opening Loop (Program 5-8) or presence loop	Maintained Signal with directional logic (see below)
8	Opening Loop (Program 5-8) or presence loop	Maintained Signal with directional logic (see below)

### 9.3.2 Directional Logic Loop B

In Loop Modes 5,6,7 and 8 the relays corresponding to Loop A and Loop B can be set to provide pulses or maintained contacts depending in what direction the vehicle travels.

Relay K2 (Terminal 19/20/21) corresponds to Loop B.

**Loop B Mode 5**

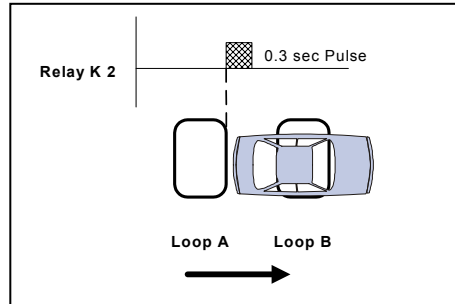

Vehicle travels from Loop A to Loop B. A 300mS pulse will be issued on relay K2 when vehicle drives from Loop A to Loop B and leaves Loop A.  
Logic:  
A/AB/B (pulse)



**Note:**

For the directional logic to function, Loop A and Loop B, it must be assured that the vehicles that use this lane trigger both loops at the same time. If this cannot be achieved a special input counting software is required. In this case, please call for further details.

**Loop B Mode 6**

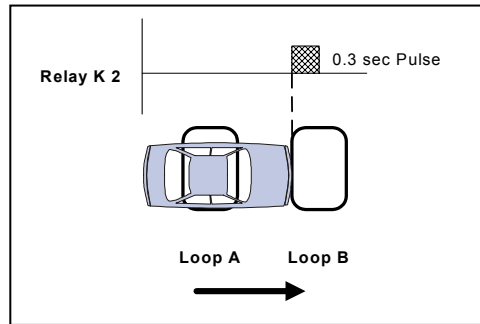

Vehicle travels from Loop A to Loop B. A 300mS pulse will be issued on relay K2 when vehicle drives from Loop A to loop B while still on Loop A.  
Logic:  
A/AB(pulse)



**Note:**

For the directional logic to function, Loop A and Loop B, it must be assured that the vehicles that use this lane trigger both loops at the same time. If this cannot be achieved a special input counting software is required. In this case, please call for further details.

**Loop B Mode 7**

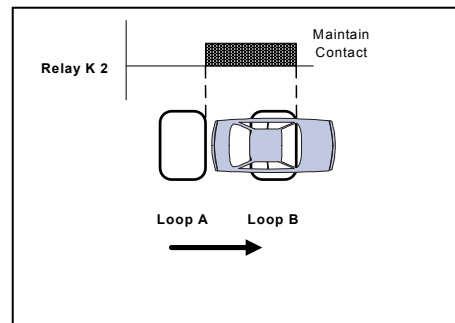

Vehicle travels from Loop A to Loop B. A maintained contact on relay K2 is made when the vehicle drives from loop A to loop B and leaves loop A while still on loop B.  
A/AB/B (Maintained Contact)



**Note:**

For the directional logic to function, Loop A and Loop B, it must be assured that the vehicles that use this lane trigger both loops at the same time. If this



cannot be achieved a special input counting software is required. In this case, please call for further details.

**Loop B Mode 8**

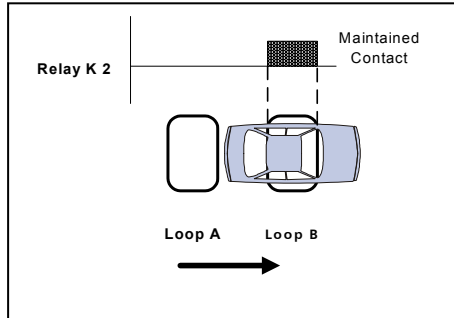

Vehicle travels from Loop A to Loop B.

A maintained contact on relay K2 is made when the vehicle drives from loop A to loop B until leaving loop A

Logic:

A/AB (Maintained contact)/B (Maintained Contact)



**Note:**

For the directional logic to function, Loop A and Loop B, it must be assured that the vehicles that use this lane trigger both loops at the same time. If this cannot be achieved a special input counting software is required. In this case, please call for further details.

## 10.0 Loop Frequency

The internal loop detectors are designed using the Multiplex technology. This means that the loops connected to one MLC controller cannot interfere with each other. Only loops connected to other detectors can interfere with the loops connected to another controller. Many factors determine loop frequency, including wire size, wire length, the number of turns, lead length, and insulation.

If multiple barriers are installed in close proximity (within 20 feet), it might be necessary to switch individual MLC controllers to low or high frequency. To determine the necessity of a frequency change the MLC controller displays the current frequency of the installed induction loops. The MLC controller operates at a frequency between 10-100kHz. The current loop frequency can be viewed by turning the rotary switch in position 8.

### 10.1 How to view the loop frequency:

1.0 Turn the rotary switch to position 8.

Display message:

Detector A XXXXX X = Current Loop frequency

2.0 To toggle between Loop A and Loop B press the white button.

3.0 To return to the normal operating mode turn rotary switch to Position 1

#### Note:

**If Loop A or Loop B is not activated the display shows "OFF".**

**The same message appears if the loop frequency is outside the operating limits (10-100kHz), not connected properly or when the loop wires are broken.**

The frequency display can be used to determine what might be the cause of loop cross talking and can also be used to prevent it from happening.

**The frequencies of two loops that use different detectors (not connected to the same MLC controller) must be at least 3kHz (3000Hz) apart.**



### 10.2 How to change the loop frequency:

The MLC controller has two DIP- switches located below terminal strip numbered 22-42. In order to reach the Dip- switches, remove the terminal strip. Follow the instructions below to remove the terminal strip and change loop frequency.

- 1.0 Turn the main supply voltage off. There is no need to disconnect any of the control-wiring going to this terminal strip.
- 2.0 Unscrew the two Phillips head screws located on each end of the terminal strip (see drawing below)

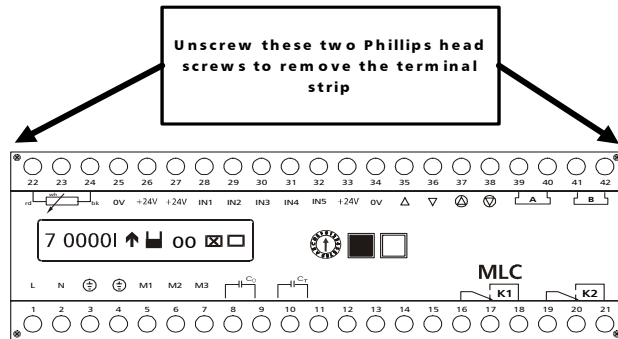

- 3.0 Pull the terminal strip up and remove it completely from the controller.
- 4.0 The two dipswitches are located on the right hand side (see drawing) below the loop connector terminals.

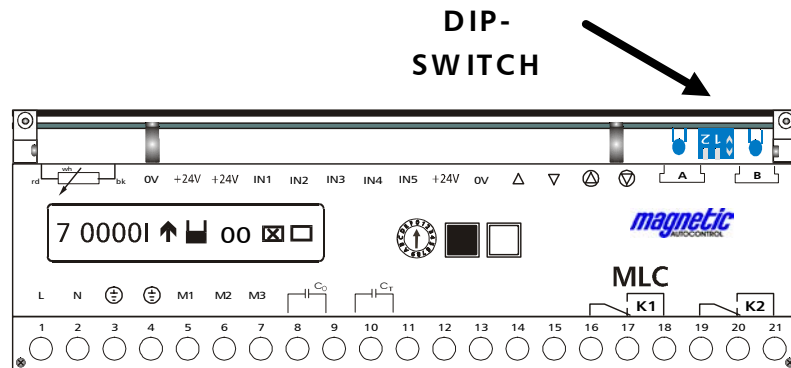

- 5.0 You are now able to change the frequency of each individual loop to "High" or "Low". See drawing below for settings.

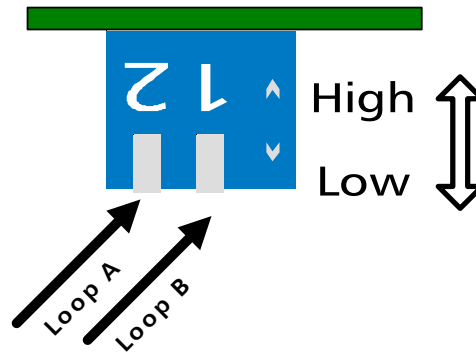

- 6.0 After changing the DIP- switch settings, replace the terminal strip, secure the Phillips head screws, return the rotary switch to position 0, and turn the main power supply on.
- 7.0 By moving the rotary switch to position 8 you can view the new frequency settings of your loops.

**Note:**

**Every change in loop frequency requires a controller reset. This can be done by simply turning the power off and turning it back on or pushing both the black and the white button and holding it until the controller resets (approx. 3sec)**



## 11.0 Relay K1 Output

The switching point of relay K1 can be set in relation to the barrier arm position. This can only be done when Loop Mode A is set to "0". The relay switching point can be set in rotary switch position B.

Follow these steps to change the switch position:

- 1. Turn the rotary switch to position B

Display Message:

1 - switch on	XX
---------------	----

XX= Current switch position setting when barrier goes up.

- 2. The barrier arm position for when the relay should turn on is shown on the display in degrees. 90 degrees the gate arm is in the full up position, 0 degrees the gate arm is in the full down position. To change the settings press the black and the white button simultaneously. A cursor below the first digit appears. To change the number, press the black button until the desired value appears on the screen

(5 degrees increments). To confirm the settings press the white button. This setting will determine when the relay switches on.

Display message:

1 - switch off    XX

3. The next display (above) shows the barrier arm position for when relay K1 should turn off again. To change the settings press the black and the white button simultaneously. A cursor below the first digit appears. To change the number, press the black button until the desired value appears on the screen (5 degrees increments). To confirm the settings press the white button. This setting will determine when the relay switches off.

Display message:

Save Y=↑ N=↓    ?

5.0 To save your changes press the Black button

6.0 To return to the normal operating mode turn rotary switch to Position 1

## 12.0 Error Code

The MLC controller comes with an error display feature that allows the user to determine internal controller errors. This Error is displayed as a hexadecimal code, which can be viewed by turning the rotary switch to position D.

For the field technician only one error code is relevant:

Display message:

Hardware error 80

If the above error message is displayed, the controller lost its boom sensor position and needs to be readjusted (see chapter 22.1 for readjusting the sensor).

For all other error messages please call Magnetic Automation Corp. for technical support.

## 13.0 Language Setting

The MLC controller can be set to multiple languages. Following are the pre-programmed standard languages:

English= English  
Deutsch = German  
Francais = French  
Espanol = Spanish

Move the rotary switch to position E to select the language of your choice.

1.0 Turn the rotary switch to position E

Display Message:

English

2.0 To change the language, press both the black and the white button at the same time. A cursor will appear at the last digit to the right.

3.0 Pressing the black button will change the display language.

4.0 To select a new language press the white button

Display message:

Save Y=↑ N=↓ ?

5.0 To save your selection, press the black button.

6.0 Return the rotary switch to position 0 for normal operation.

## 14.0 Extended Menu settings:



**Note:**

To access the extended operating menu, the black button must be pressed while the rotary selector switch is turned to the required position.

Safety Angle: Disabling of safety device in down position Pos. _1	Adjustment of the angle (boom position) at which the safety device (induction loop, light beam etc.) should be disabled before the boom reaches the complete down position.
Operating hours Pos. _2	Displays the total time in hours the barrier was turned on. Timer is not resettable.
Operating cycle counter. Pos. _3	Displays the total cycle count of the barrier. This counter is indexed every ten (10) cycles, and is not resettable.
Brake settings. Pos. _4	This enables you to read the current brake settings, which might be helpful to determine gate failures.
Not available Pos. _5,6,7,8,A	These positions do not have any function.
Brake fine tuning Pos. _B	This position allows you to fine-tune the brake settings in case the brake might not be satisfactory. Positive numbers: Gate will brake sooner Negative numbers: The gate will brake later.
Reset Pos. _C	Choice of resetting behavior after the power is restored to the gate. Signal Reset = The gate will reset after the first Input is made. Auto Reset = the gate will reset (close) when power is restored.
Test Mode Pos. D	This can be used to cycle the gate automatically.
Motor Pos. E	This menu can be used to adjust the potentiometer.



### 14.1 Adjusting the safety angle:

This setting allows the user to adjust the boom position in which the controller disables the safety devices. This setting allows the user to increase the safety of the operation or prevent tailgating from happening. To increase safety, the cut off angle is smaller; to prevent tailgating, the cut of angle is higher (i.e. the safety device is disabled sooner). **To disable the safety cut off sooner to prevent tailgating will also increase the possibility that vehicles are being hit by the gate arm.** This angle is adjustable between 10°- 80° in 5° increments. The down position equals 0° and the complete up position 90°. To change the setting follow steps below.

1.0 Press and hold the black button while turning the rotary switch to position 1  
Display Message:

Angle safety    XX                    X = Current setting

2.0 Press the black and the white button simultaneously. A cursor below the first digit appears. To change the number, press the black button. To confirm the settings press the white button.

Display Message:

Save Y=↑ N=↓    ?

3.0 Press the black button to save the changes.

4.0 Return the rotary switch to position 0 for normal operation.



### 14.2 Operating hour display:

The total time the controller was turned on can be viewed at rotary position 2. The counter is not resetable.

1.0 Press and hold the black button while turning the rotary switch to position 2.

Display Message:

Hours	XXXXX.X	X = Current operating hours
-------	---------	-----------------------------

2.0 Return the rotary switch to position 0 for normal operation.

### 14.3 Gate Cycle counter:

This cycle counter displays the gate cycles made with this controller. The counter is not resetable. It indexes every 10 cycles.

To view the counter, follow these steps.

1.0 Press and hold the black button while turning the rotary switch to position 3.

Display Message:

Cycles	XXXXX	X = Current cycle count
--------	-------	-------------------------

2.0 Return the rotary switch to position 0 for normal operation.

## 14.4 Reading the Brake Points:

All MIB barriers self adjust to the optimal brake points depending on boom length, boom weight, Barrier model and spring adjustment. The brake points must be within a pre-programmed range. Following table shows the range for each of the barrier models:

Barrier Model	Brake Point Up	Brake Point down
MIB30 50Hz	40-240	60-280
MIB30 60Hz	80-290	90-280
MIB40 50Hz	40-150	60-180
MIB40 60Hz	70-150	50-200

To view the current brake points follow these steps:

1.0 Press and hold the black button while turning the rotary switch to position 4.

Display Message:

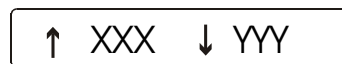

XXX = Current brake point  
gate position UP  
YYY = Current brake point  
gate position DOWN

2.0 Return the rotary switch to position 0 for normal operation



### Note:

**Comparing the displayed brake points with the brake point range of the individual barrier model can determine possible malfunctioning of the barrier. If the brake points are out of range, please follow the instructions in chapter 22.1.**

## 14.5 Resetting the barrier after power failure:

The MLC controller can be set to two different resets after a power failure. Ex factory, the setting is "Signal Reset".

### Signal Reset:

If the barrier is in the fully closed position after the power is restored the controller will accept all inputs immediately after booting the software.

If the barrier is not in the fully closed position the gate will open and remain open until the following occurs:

1. Reset by pressing the black and the white button simultaneously for approx 2sec.
2. Closing input on IN3
3. Passing through the safety/closing device (external or internal).

Before any of the above steps are taken, the display will show the following:

R Reset Requested

The "RESET REQUESTED" display flashes in a 1sec. Interval.

Any of the above actions will reset the controller to the normal operation mode.

The other reset option is

### Auto Reset:

After the power is restored, the barrier reacts to any activated input independent of the barrier arm position. If no opening input is activated and no object is in the safety zone the barrier will close.

Please follow these steps to select the reset mode:

1.0 Press and hold the black button while turning the rotary switch to position C.

Display Message:

Signal Reset

2.0 Press the black and the white button simultaneously. A cursor appears on the right hand side of the display. To change the setting, press the black button. To confirm the settings press the white button.

Display message:

Save Y=↑ N=↓ ?

3.0 Press the black button to save the changes.

4.0 Return the rotary switch to position 0 for normal operation.

## 14.6 Test Mode

The MLC controller offers the feature to run the barrier in a test mode without having to install an open close timer or other equipment. During this test mode, the barrier will open and close continuously. This can be used for equipment demonstration or testing.

Please follow these steps to set the controller in test mode:

1.0 Press and hold the black button while turning the rotary switch to position D.

Display Message:

Test Mode X

X= Current Program Mode setting

2.0 To change to Test Mode press the black and white button simultaneously.  
Display Message:

Test Mode 9

9= Test Mode

3.0 Release both buttons. The number has now changed to 9, which symbols the test mode is set.

4.0 Return the rotary switch to position 0  
Display Message:

9 0000I ↑ ▣ 00 □ □

5.0 If no input is activated and no object is in the safety zone, the barrier will now start to cycle up and down.

6.0 To return to the normal operation mode, simply turn the rotary switch to position 1 and then back to position 0.

## 15.0 Installing the Induction Loops

### 15.1 General induction loop functionality

The Loop detectors operate on the principle of inductance. The detector monitors an insulated electrical wire, placed on or below the road surface (LOOP). Any metallic object, such as a car, which passes through the field will absorb electromagnetic energy and simultaneously decrease the inductance and increase the resonant frequency of the loop. For most conventional installations, when the inductance or frequency changes beyond a preset threshold in the detector electronics, the detector indicates that a vehicle has been detected.

**Note:**

**Only metallic objects can be detected. The loop frequency change depends on the size and form of the to be monitored object (i.e. car) not on the material mass, which does not influence the loop.**

The micro controller system self adjusts to the connected loop. Many factors determine loop inductance, including wire size, wire length, the number of turns, lead length, and insulation.

Changes in loop inductance due to temperature or aging are automatically compensated.

Detectors with multiple channels (i.e. dual channel) are monitored using the MULTIPLEX METHOD, which eliminates the interference (cross-talk) between the loops connected to this detector.

### 15.2 Loop Inductance

#### 15.2.1 Inductance

Inductance is the resistance to the change of current flow. When a current is applied to a conductor (wire), a magnetic field is formed around the conductor (wire). If the current source is removed, the magnetic field collapses into the wire trying to maintain the current flow. By winding several turns of the wire into a coil, the magnetic field is intensified which increases the inductance.

The loop inductance can be measured with an inductivity meter. The unit of measurements is the Henry (h). The inductance depends on the loop perimeter and number of turns. A bigger loop with more turns has a higher Inductance.

### 15.2.2 Vehicle detection

When a vehicle enters the loop, the body and frame provide a conductive path for the magnetic field; causing a loading effect, which in turn causes the loop inductance to decrease. The decreased inductance causes the resonant frequency to increase from the nominal value. If the frequency change exceeds the threshold set by the sensitivity setting, the detector module will output a detect signal.

There has been a misconception that an inductive loop requires a mass of metal for detection. Placing a single wire around the perimeter of the loop and shorting the ends together will quickly disprove the misconception. The single wire forming a shorted turn provides a current path for the magnetic field; thus causing a loading effect similar to that of a vehicle. The shorted turn effect of the single wire coil in the proximity of the loop acts much like a shorted turn secondary of a transformer.

### 15.2.3 Wire Turns required for loops

The Inductive loop detectors will tune from 50  $\mu\text{H}$  to 500  $\mu\text{H}$  ( $\mu\text{H}$  = microHenry). It is preferable that the loop and lead-in have a minimum of approximately 50  $\mu\text{H}$  for stability. The loop inductance should be equal to or greater than the lead-in inductance.

If the inductance of the loop exceeds the requirements above, a proper functioning of the detector cannot be guaranteed.

The loop inductance also influences the loop sensitivity. The best results are between 100 and 300  $\mu\text{H}$ .

### 15.2.4 Loop Inductance calculations

The number of turns required in the loop is dependent on the loop size. The loop inductance can be calculated as follows:

$$L = P/4 (t^2 + t)$$

L = Inductance (micro Henries)  
 P = Perimeter (feet)  
 t = Number of turns

The formula can be simplified to:  $L = PK$   
 Substituting a constant K for  $(t^2 + t)/4$   
 Filling in the Number of Turns and calculating K:

Number Of Turns (t)	k (constant) $k = (t^2 + t)/4$
2	1.5
3	3
4	5
5	7.5
6	11.5
7	14

Example: 4' x 8' with 4 turns  
 $L = PK$   
 $P = 4' + 4' + 8' + 8' = 24$  feet  
 $K = 5.0$   
 $L = 24 \times 5.0$   
 $L = 120$  micro henries

		NUMBER OF TURNS					
		2	3	4	5	6	7
PERIMETER FEET	10	15	30	50	75	115	140
	20	30	60	100	150	230	280
	30	45	90	150	225	345	420
	40	60	120	200	300	460	560
	50	75	150	250	275	575	700
	60	90	180	300	450	690	840
	70	105	210	350	525	805	980
	80	120	240	400	600	920	1120
	90	135	270	450	675	1035	1260
	100	150	300	500	750	1150	1400



Use the highlighted values to determine the number of turns required. ALWAYS USE AT LEAST 2 TURNS. In addition to the above result, the inductivity of the wires used in the loop must be added. Depending on the used wire, it is between 1 – 1.5  $\mu$ H per every three (3) feet.

### 15.3 Loop Detector Sensitivity

The MLC loop detector comes with multiple adjustable sensitivity settings. This means that only vehicles will be detected when the relative frequency change (difference between loop frequency with vehicle and without) is higher than the adjusted sensitivity.

For example:

If the sensitivity of a loop detector is adjusted to 0.05%, only vehicles that change the loop frequency by more than 0.05% will be detected.

**Note:**

To ensure a failsafe detection of vehicles, the value of the Relative Frequency Change should be at least 10 times higher than the adjusted loop sensitivity



If the value is lower, it might not detect every vehicle (i.e. Pick-Up trucks). Wrong loop dimensioning or geometry, not enough windings, not enough clearance to metal objects within the road (i.e. steel reinforcement, sewer grill etc), can cause a low Relative Frequency Change value.

The following table shows the MLC detectors Sensitivity Levels which can be set at rotary switch position 4 for Loop A and 5 for Loop B:

Sensitivity level MLC10/11-U100	Sensitivity
9	0,01%
8	0,015%
7	0,03%
6	0,06%
5	0,09%
4	0,15%
3	0,22%
2	0,3%
1	0,9%
0	1,8%

### 15.4 Installing a Induction Loop

#### 15.4.1 Usage of Pre-manufactured Loops

Any pre-manufactured (formed) loop can be used as long they meet our requirements explained in this manual.

Please refer to loop manufacturers Installation Instructions.



### 15.4.2 Self-Made Loops

A loop can be manufactured from a single AWG 14-18 stranded XLPE insulated wire rated at 600V. The insulation type XLPE (cross-linked polyethylene) is highly recommended due to its higher quality insulation and higher resistance to abrasion, heating oil and gasoline. The wire gauge is not important to the operation of the loop detector but the wire should maintain its integrity under the pavement stress.

Because asphalt is more flexible than concrete it is recommended that, a heavier gauge wire is used for loop installations in asphalt.

The inductance of the loop shall be between 70 and 500  $\mu\text{H}$ , which is usually achieved by having three to five turns in the coil. The loop resistance should be lower than  $2\ \Omega$ . The loop resistance should be measured after installing the loop but before sealing. The Loop Insulation Resistance must be measured to earth ground. The Insulation Resistance against earth ground must be a minimum of  $5\ \text{M}\Omega$  at 500 Volts. If this is not the case, the loop insulation might be damaged. (See chapter 16.2 Loop Inductance).

The temperature of the sealing must be below the temperature of the wire insulation.

To lessen the stress and abrasion of the loop wire the  $90^\circ$  corners shall be cut at a  $45^\circ$  angle or a core drilled with a minimum of 1.5" diameter (See drawings below).

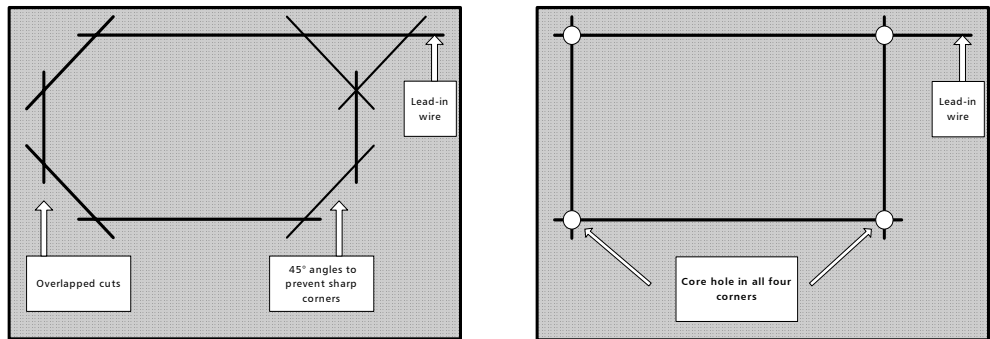

### 15.4.3 Loop Lead Wires

The loop lead-in wire has a significant role to the functionality of the loop.

Following are some important points for installing loop leads:

The loop lead-in wire must be twisted about 7 times per ft up to the point where the wires connect to the detector.

Leads of multiple loops should not use the same cable or conduit. If it is not possible to have separate conduits for multiple loop leads, a shielded twisted-pair wire must be used for each loop.

The lead-in length should not exceed 50 feet.

Long leads can decrease the sensitivity therefore; the leads should be as short as possible.

**Note:**

It is necessary to cut the leads to the proper length. Excessive long leads looped before it is wired to the detector will decrease the loop functionality.



Do not run a loop lead through the same cut of another loop:

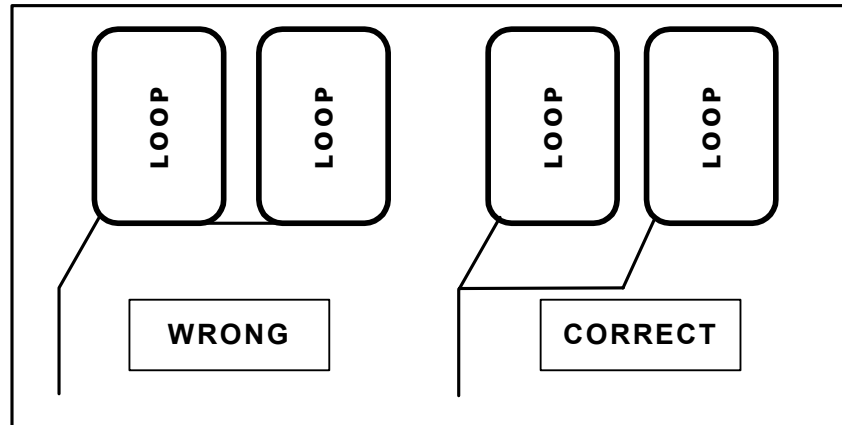

#### 15.4.4 How deep should the loop wires be installed?

The deeper the wires are below the road surface the more they are protected from road surface wear and the elements. The top wire should be a minimum of 1 inch below the road surface.

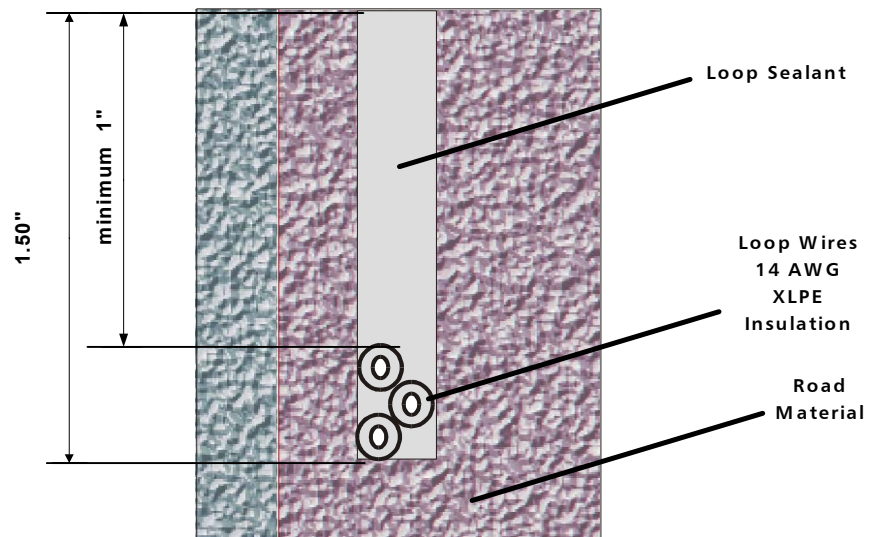

**Note:**

Nonconductive materials such as concrete and asphalt will not influence the loop fields. Installing the loop one inch deeper (e.g. 3" depth not 2" depth) would have the same result as raising the vehicle one inch above the pavement surface.

**15.4.5 Loop distance from objects:**

A minimum distance of 1ft between the loop and all metal objects (steel reinforcements, sewer grill etc.) must be kept. If this is not the case the loop sensitivity can decrease significantly and a proper functioning of the loop cannot be guaranteed.

The loop and loop leads must not be installed near to any underground high voltage cables.

The distance between loops and barrier housings or barrier arms should be a minimum of 10".

The following rule should be observed:

**The longer the loop, the greater the spacing must be between the gate and the loop.**

Following is a typical installation that shows how the loops should be installed. (see below).

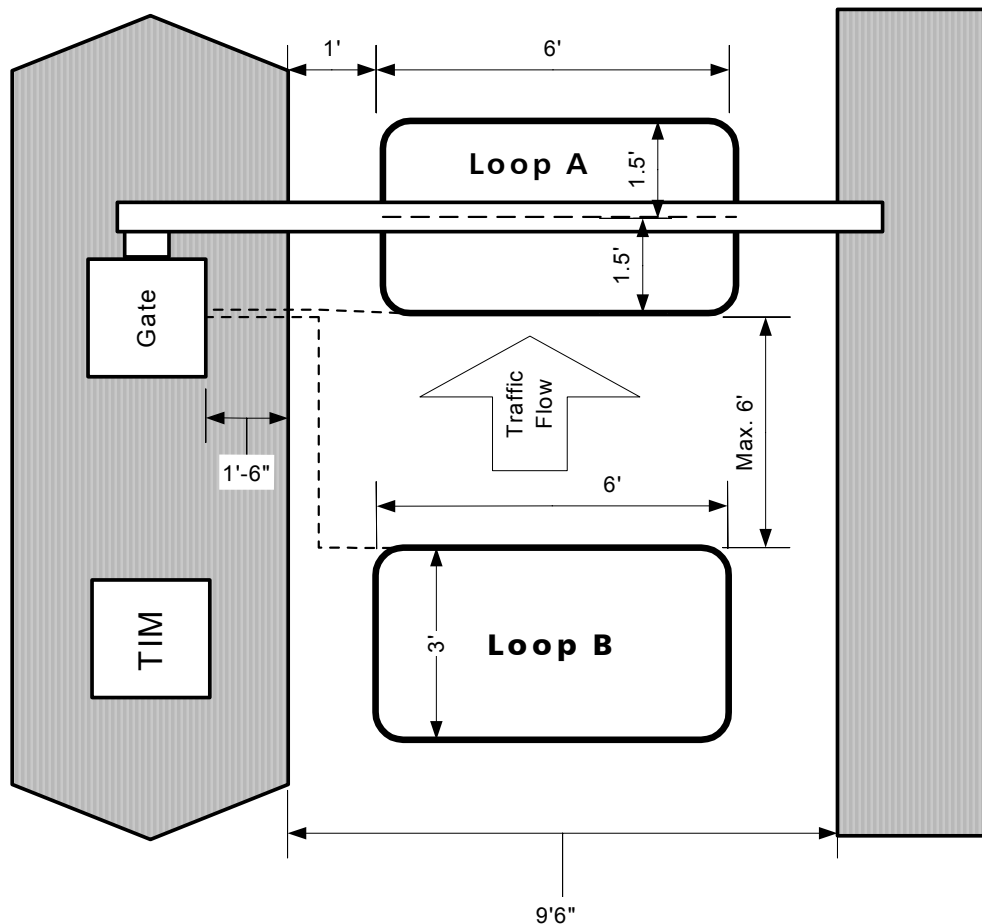

## 16.0 Commissioning

### 16.1 Commissioning procedure

Once the barrier has been installed, the barrier boom attached and all electrical wiring work (including the installation of induction loops) have been completed, according to the instructions; the barrier can be put into operation.

To avoid the risk of injury and damage arising from any unintentional barrier movements during initial operations, all persons, and objects should be kept clear of the barrier.



### 16.2 Messages displayed during the start-up routine

The following messages are displayed during the controller start-up routine:

1. Display message:

\*\*\* MAGNETIC\*\*\*

1. Display message:

Hard A, Boot 0002

Hard A- Hardware version A  
Boot 0002 = Software version 0002

2. Display Message:

MLC10-100 S24008

MLC10-100 = Controller Type  
S24008 = Software Parameter

4. Display Message

0009.0003 00

0009.0003 = Software Version  
00 = Parameter Version

5. Display Message:

MIB30 60Hz

MIB30 = Barrier Model  
60Hz = Voltage, frequency

6. Display Message:

7 0000I ↑ ▣ 00 □ □

See chapter 4.2 Display information

**Note:**



Ex factory, the barrier is shipped with the reset function as “SIGNAL RESET” (see chapter 14.5 RESETTING THE BARRIER). After resetting the controller, the barrier is now fully functioning.

Please use the wiring diagrams displayed in chapter 5.0 PROGRAMMING MODES for Input wiring.

### 16.3 Standard Configuration:

Following are the standard controller configuration ex-factory:

#### 16.3.1 Parking or access control configuration:

Program Mode:	7	see chapter 5.1.7
Loop A Sensitivity:	5	see chapter 8.0 and 15.3
Loop B Sensitivity:	5	see chapter 8.0 and 15.3
Loop Mode A:	2	see chapter 9.0
Loop Mode B:	2 presence	see chapter 9.0
Safety Angle:	15°	see chapter 15.1

#### Note:

**If your installation requires different setting, please follow the instructions in the corresponding chapters.**



## 17.0 Installation Example:

### 17.1 Free exit or entry configuration:

For a free entry or exit application, please follow these steps:

#### 1.0 Program Mode setting:

Mode 5, 6, 7 and 8 will work as free exit or entry application, depending on the application, set the mode accordingly. Please read chapter 5.1.5, 5.1.6, 5.1.7 and 5.1.8 for details.

Typical is Program Mode 5, which will close after the adjustable hold open timer elapses if no vehicle passed through the safety/closing loop. If this installation requires that, the gate should stay up if no vehicle passes through the safety/closing loop then choose Program Mode 7.

#### 2.0 Loop Mode A setting:

Depending on the installation requirements, set Loop Mode A to meet those specifications. Please read chapter 9.0 for further details.

Typical is Loop Mode 2, which issues a potential free maintained contact on relay K1 when a car is on the Loop.

#### 3.0 Loop Mode B setting:

Depending on the installation requirements, set Loop Mode B to meet those specifications. Please read chapter 9.3 for further details.

For free exit or entry, Loop Mode B must be set to "OPENING LOOP". The output relay is typically set to 2 to receive a potential free maintained output on relay K2 whenever a vehicle is on the loop.

Typical is Loop Mode 2, which issues a maintained potential free contact whenever a vehicle is on the loop.

#### 4.0 Hold Open Timer setting:

If this installation requires that the gate closes automatically after receiving an opening command without a vehicle passing through the safety-closing zone, set Program Mode to 5 or 6 and set the hold-open timer according to your requirements. Please read chapter 7.0 for further details

Typical hold open timer setting is 35sec.

#### Note:

**After all settings are done, return the rotary switch to position 0 for normal operation.**

**The barrier is now in full operation mode.**



### 17.1.1 Free entry or exit Lane Layout

The drawing below shows a typical lane layout for a fee entry or exit application.

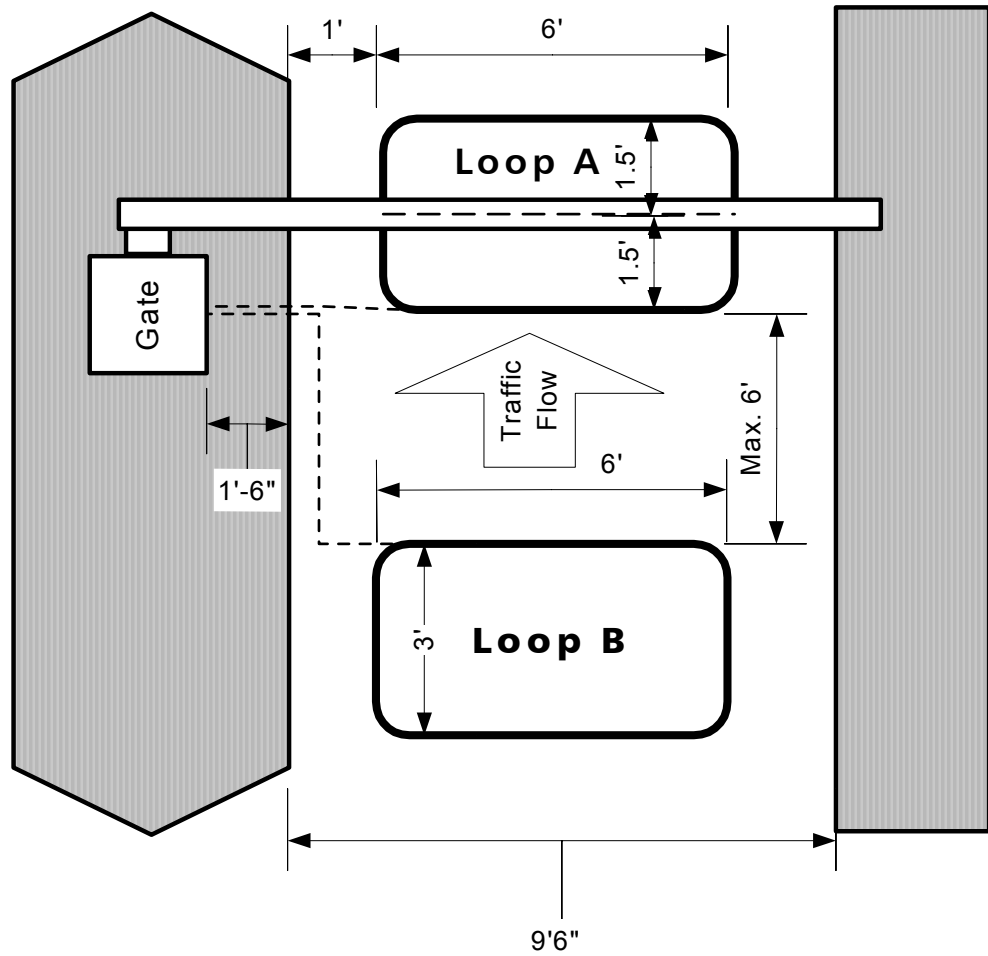

### 17.1.2 Free entry or exit wiring diagram:

Below is a Free entry or exit lane wiring diagram with a device to open the barrier if configured as free exit.

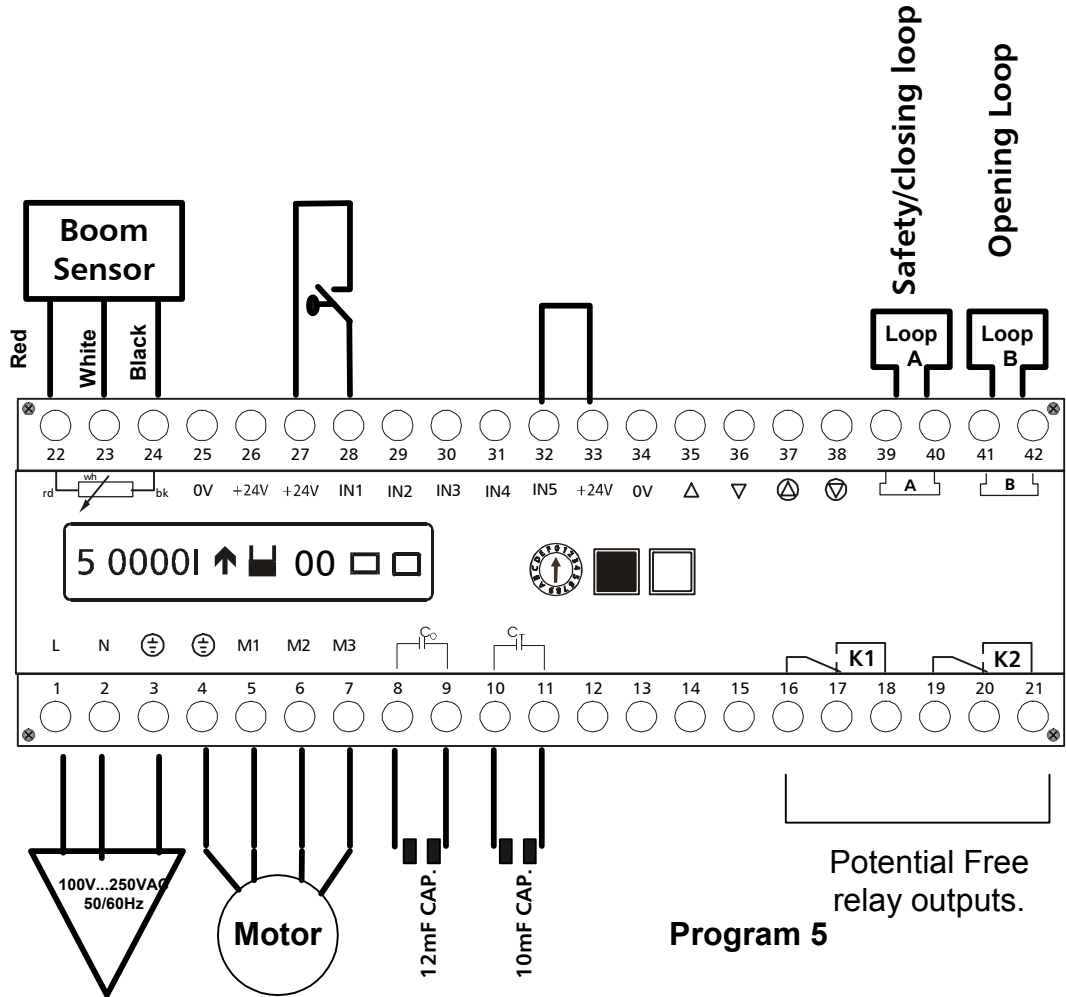



### **17.2 Entry or exit with access control:**

For an access controlled entry or exit, do the following:

#### **1.0 Program Mode setting:**

Mode 5, 6, 7 and 8 will work for this application, depending on the application, set the mode accordingly. Please read chapter 5.1.5, 5.1.6, 5.1.7 and 5.1.8 for details.

Typical is Program Mode 7, which will remain open if no vehicle passed through the safety/closing zone. If this installation requires that the gate should automatically close if no vehicle passes through the safety/closing loop, choose Program Mode 5.

#### **2.0 Loop Mode A setting:**

Depending on the installation requirements set Loop Mode A to meet those specifications. Please read chapter 9.0 for further details.

Typical is Loop Mode 2, which issued a potential free maintained contact on relay K1 when a car is on the Loop. This can be used to reset the access control equipment.

#### **3.0 Loop Mode B setting:**

In an access control application, Loop B is used as presence (arming) loop. Please read chapter 9.3 for further details.

To arm the access control equipment when a vehicle is present set the Loop Mode to 2 and "PRESENCE LOOP". This will issue a potential free maintained contact at Relay K2 whenever a vehicle is on the loop.

Typical is Loop Mode 2, which issues a maintained potential free contact at relay K2 whenever a vehicle is on the loop.

#### **4.0 Hold Open Timer setting:**

If this installation requires that the gate close automatically after receiving an opening command without a vehicle passing through the safety closing zone, set Program Mode to 5 or 6 and set the hold-open timer according to your requirements. Please read chapter 7.0 for further details.

Typical hold open timer setting is 35sec.

### 17.2.1 Access Control Lane layout

The drawing below shows a typical lane layout for an access control entry or exit.

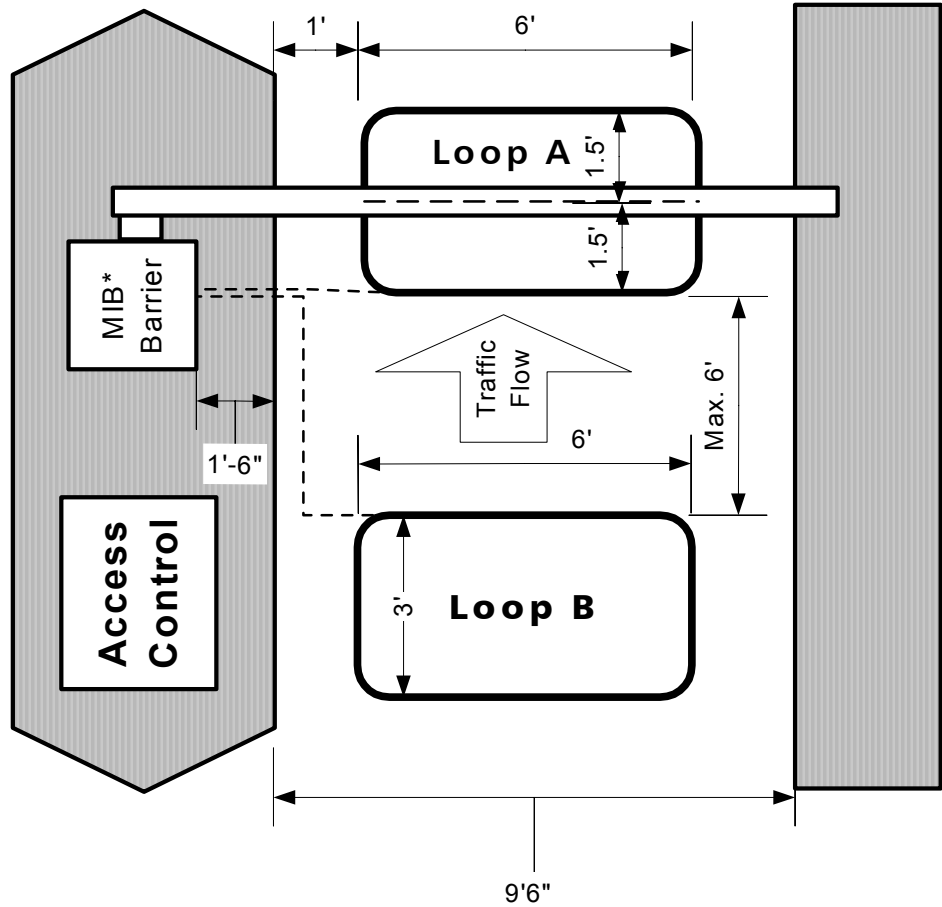

### 17.2.2 Access Control Lane wiring diagram

Below is an Access Control entry exit-wiring diagram.

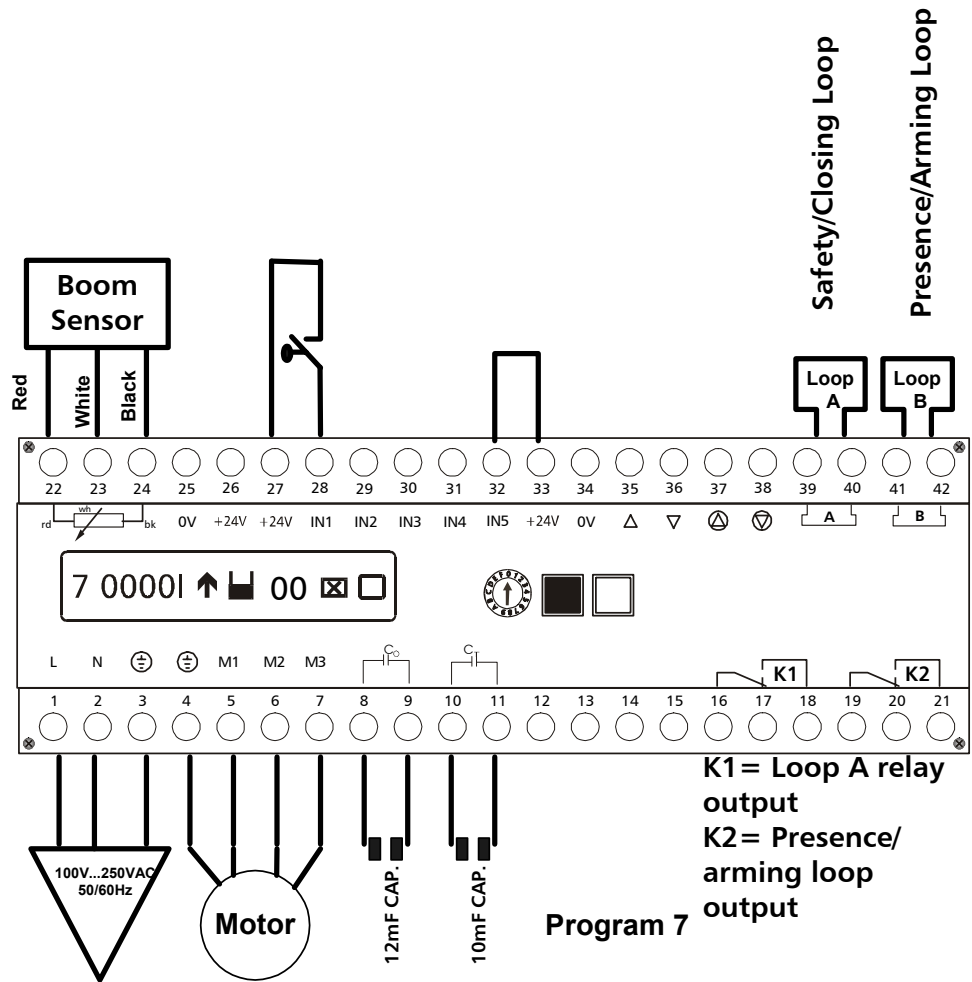

## 17.3 Access Control one direction free in/out other direction

### 1.0 Program Mode setting:

Mode 6 and 8 are recommended for this application. See chapter 5.1.6, and 5.1.8 for details. If the installation requires a presence loop to arm the access control equipment an additional loop detector is required.

Typical is Program Mode 6, which will close after the adjustable hold open timer elapses if no vehicle passed through the safety/closing loop. If this installation requires that, the gate should stay up if no vehicle passes through the safety/closing loop choose Program Mode 8.

### 2.0 Loop Mode A setting:

Loop A can only be used for the safety/closing function of the barrier.

Depending on the installation requirements, set Loop Mode A to meet those specifications. Please read chapter 9.0 for further details.

Typical is Loop Mode 2, which issues a potential free maintained contact on relay K1 when a car is on the Loop.

### 3.0 Loop Mode B setting:

Depending on the installations requirements, set Loop Mode B to meet those specifications. Please read chapter 9.3 for further details.

For free exit or entry, Loop Mode B must be set to "OPENING LOOP". The output relay is typically set to 2 to receive a potential free maintained output on relay K2 whenever a vehicle is on the loop.

Typical is Loop Mode 2, which issues a maintained potential free contact whenever a vehicle is on the loop.

### 4.0 Hold Open Timer setting:

If this installation requires that the gate close automatically after receiving an opening command without a vehicle passing through the safety closing zone, set Program Mode to 6 and set the hold-open timer according to your requirements. Please read chapter 7.0 for further details

Typical hold open timer setting is 35sec.

### Note:

**After all settings are done return the rotary switch to position 0 for normal operation.**

**The barrier is now in full operation mode.**

**If the installation requires a presence loop to arm the access control equipment an additional loop detector is required.**

**No external wiring of the opening loop is required. The MLC controller handles the opening of the barrier internally.**



### 17.3.1 Access Control In Free Out Lane Layout

Drawing below shows a typical lane layout:

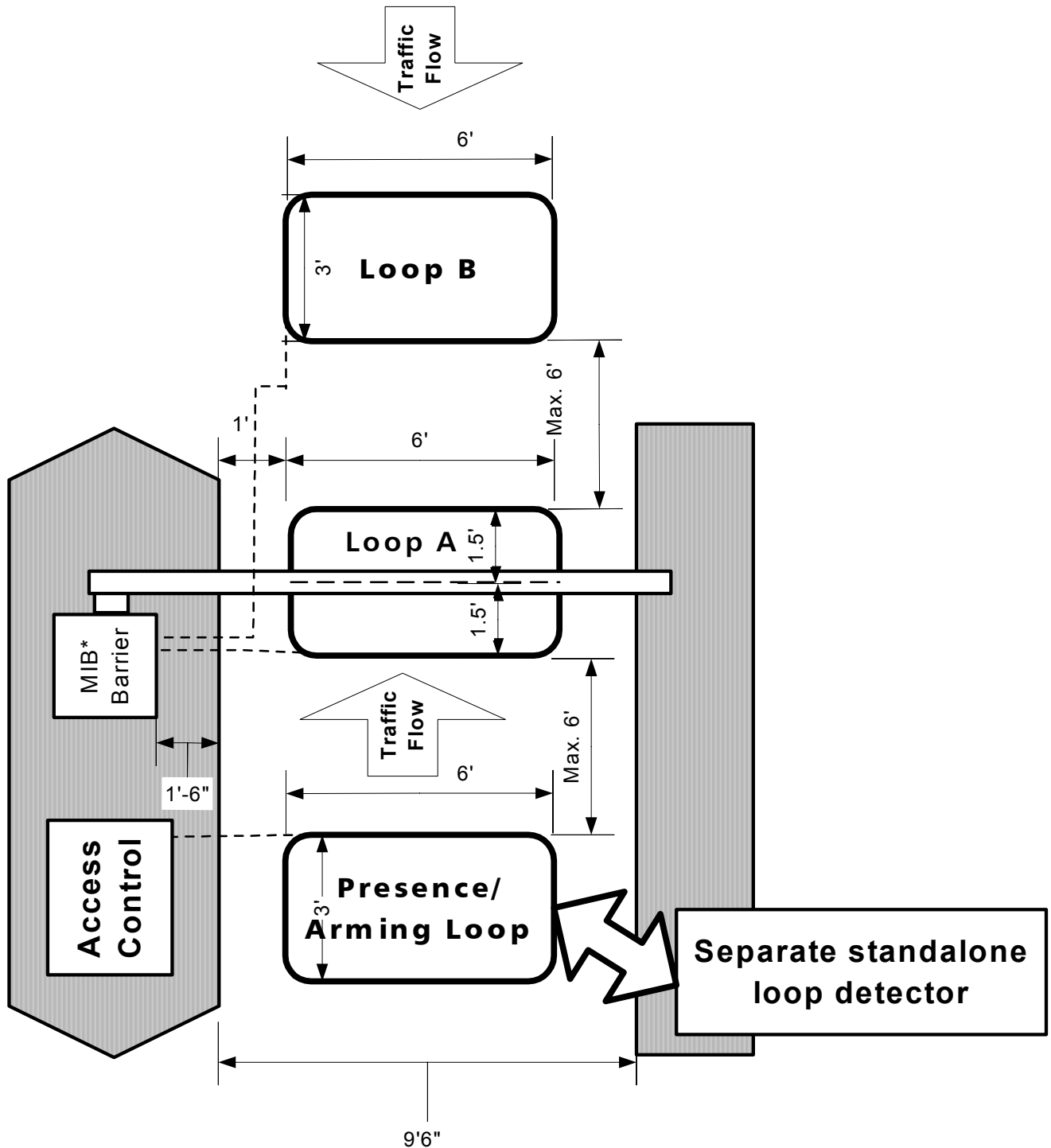

### 17.3.2 Access Control In Free Out Lane wiring diagram

Below is an Access Control "IN" free "OUT" wiring diagram:

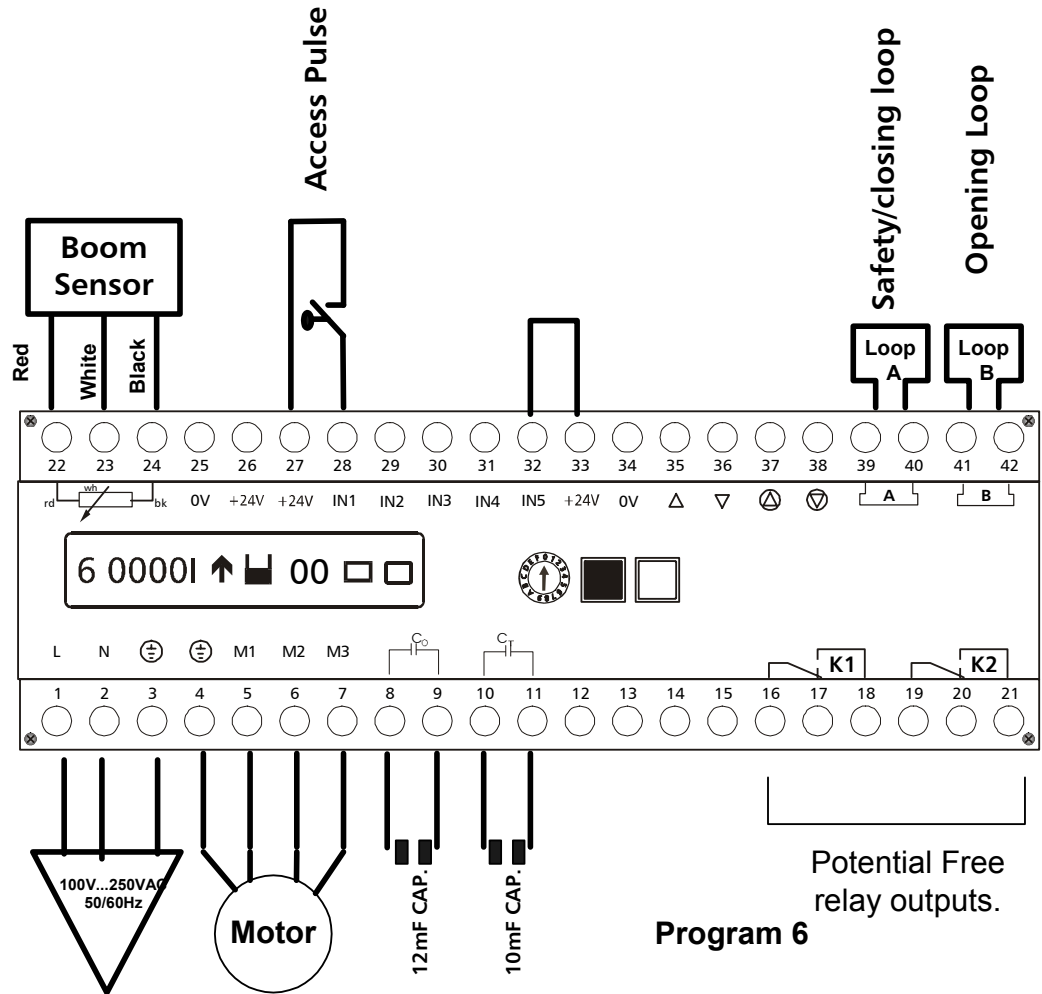

Program 6

### 17.4 Master Slave configuration

In a master slave configuration, the master barrier controls the slave barrier. All access control wiring must go to the master barrier. An additional relay (see chapter 18.4.2) is required to achieve this function. The Master can be set in Mode 5 through 8 and the Slave barrier must be set to Mode 1.

#### 1.0 Program Mode setting:

##### Master Barrier:

Mode 5, 6, 7 and 8 will work for this application. Depending on the application, set the mode accordingly. Please read chapter 5.1.5, 5.1.6, 5.1.7 and 5.1.8 for details.

Typical is Program Mode 7, which will remain open if no vehicle passed through the safety/closing zone. If this installation requires that the gate should automatically close if no vehicle passes through the safety/closing loop choose Program Mode 5 or 8.

##### Slave Barrier:

The slave barrier will only function in Program Mode 1.

#### 2.0 Loop Mode A setting:

##### Master Barrier:

Depending on the installation requirements, set Loop Mode A to meet those specifications. Please read chapter 9.0 for further details.

Typical is Loop Mode 2, which issues a potential free maintained contact on relay K1 when a car is on the Loop. This can be used to reset the access control equipment.

##### Slave Barrier:

The Loop Mode A for the slave barrier should be 0 (= disabled). In wide lanes that require more than one loop, connect them in series to the Master MLC controller.

#### 3.0 Loop Mode B setting:

##### Master Barrier:

In an access control application, Loop B is used as a presence (arming) loop. Please read chapter 9.3 for further details. If no presence, (arming) loop is required set Loop Mode B to 0.

To arm the access control equipment when a vehicle is present you must set the Loop Mode to "2" and "PRESENCE LOOP". This will issue a potential free maintained contact on relay K2 whenever a vehicle is on the loop.

In a free entry or exit application, Loop B must be set to "OPENING LOOP" and the Mode depends on the application.

Typical is Loop Mode 2, which issues a maintained potential free contact at relay K2 whenever a vehicle is on the loop.

##### Slave Barrier:

Loop B must be set to 0 (= disabled).

#### **4.0 Hold Open Timer setting:**

##### **Master Barrier:**

If this installation requires that the gate closes automatically after receiving an opening command without a vehicle passing through the safety-closing zone, set Program Mode to 5 or 6 and set the hold-open timer according your requirements. Please read chapter 7.0 for further details.

Typical hold open timer setting is 35sec.

##### **Slave Barrier:**

The Slave barrier is operated in Program Mode 1, which does not support this feature, but the slave barrier will operate simultaneously with the Master barrier.



### 17.4.1 Master/Slave Lane layout

Following is a drawing on how to layout the lane for a Master/Slave application

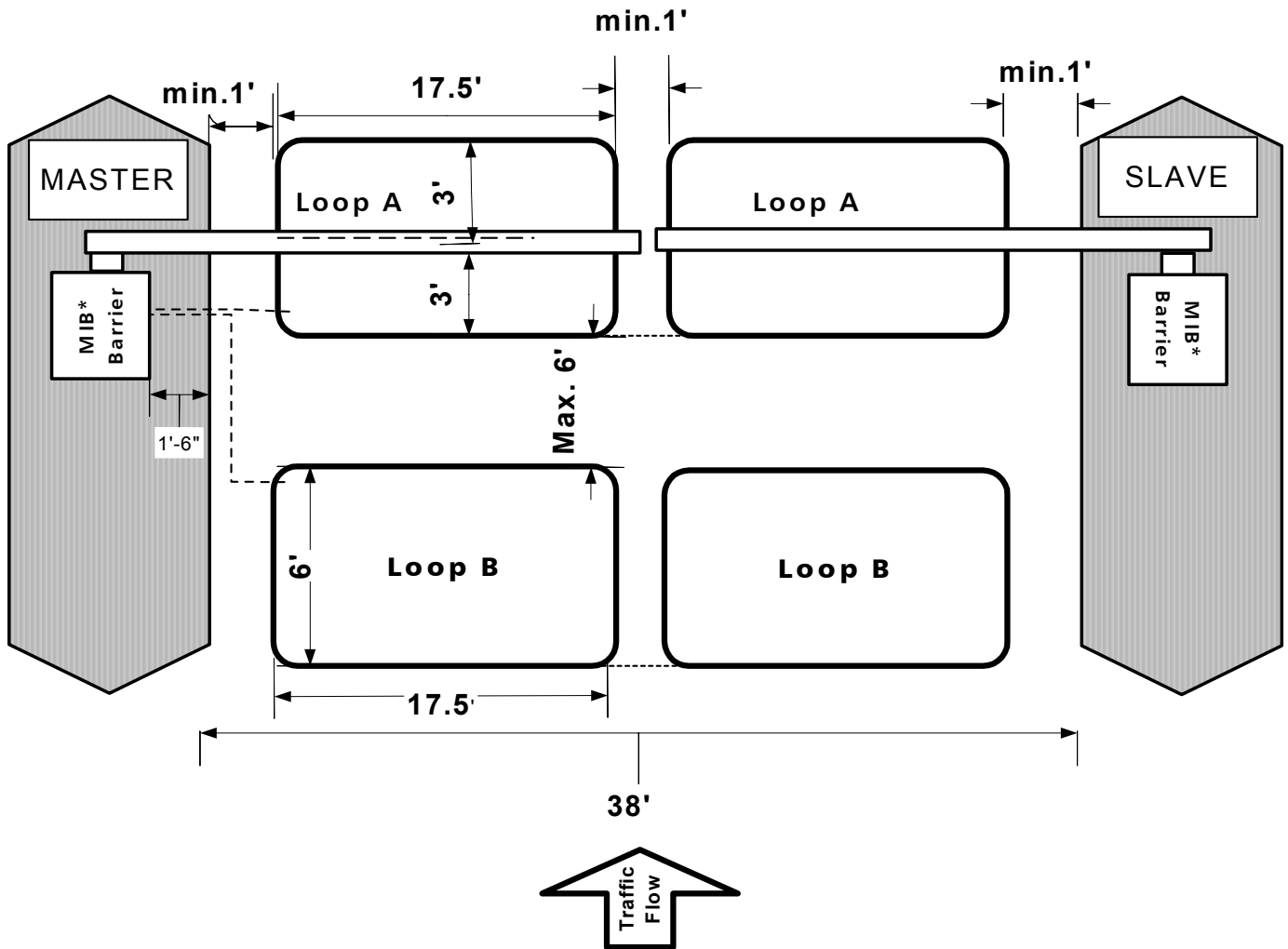

### 17.4.2 Master Slave wiring diagram

Below is a Master/Slave configuration-wiring diagram

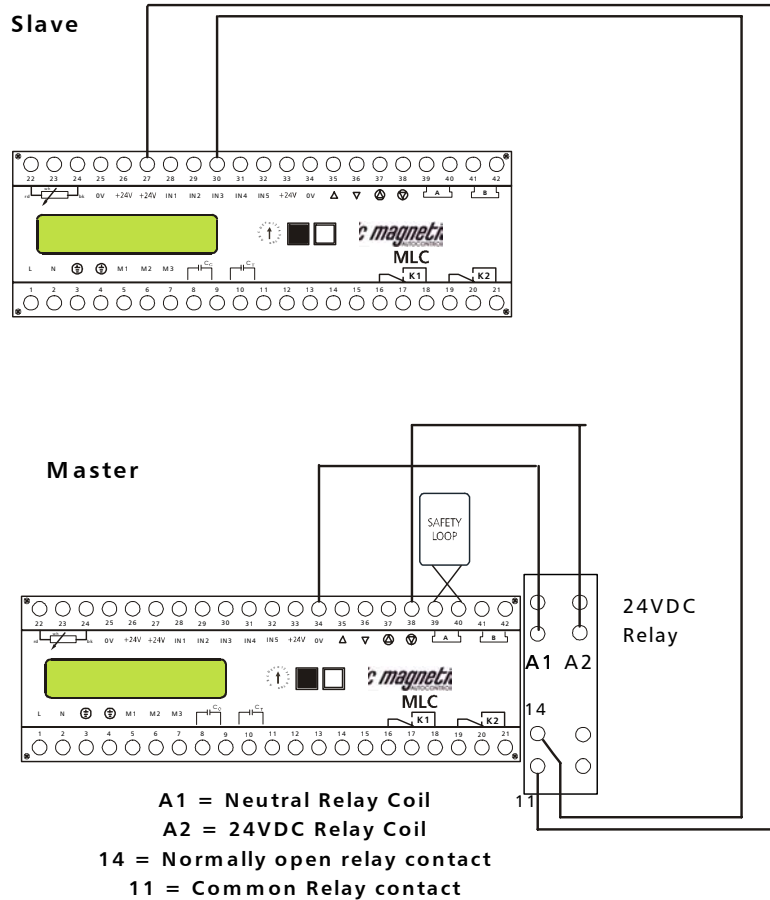

Slave:  
 Program 1  
 Loop mode A & B = 0  
 (Disabled)

Master:  
 Program: 5-8

Loop Mode A: 2  
 Loop Mode B: as desired

## 18.0 MIB\* barrier with boom Lock mechanism

The MIB\* barriers can be operated with the boom locking mechanism. Please see Magnetic Info sheet MM5141 for details.

The Info sheet is attached to this manual if a MIB\* barrier with locking mechanism was purchased.

Following is a wiring diagram showing the connection of the MLC controller and the MMV1C-100 boom-locking controller:

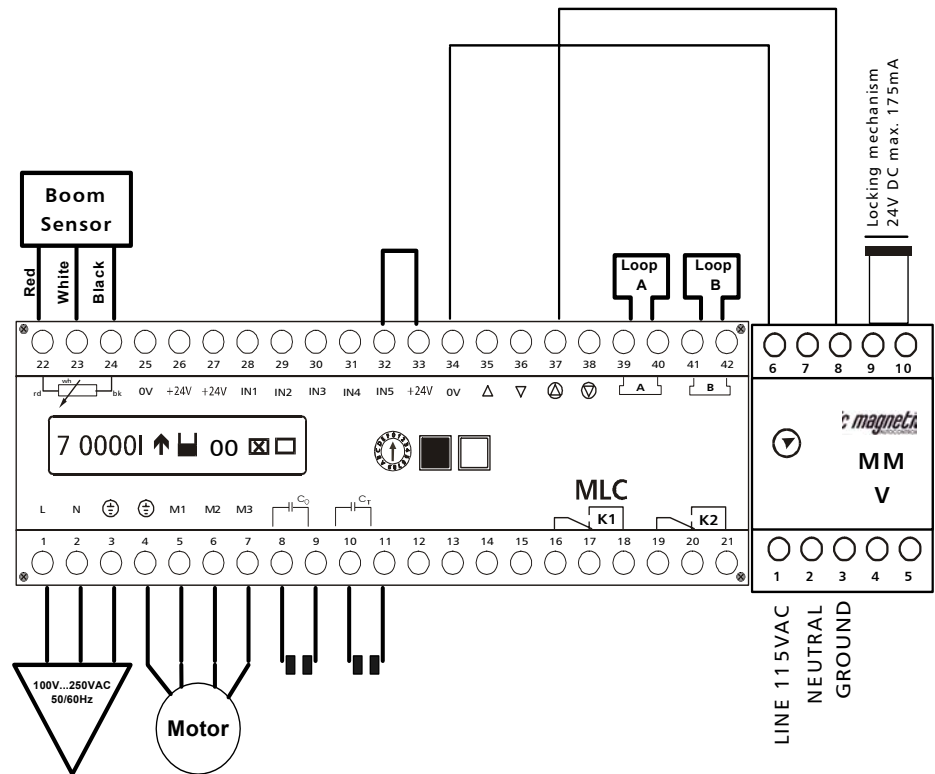

## 19.0 MIB\* barrier with boom lights

The MIB\* barriers can be operated with the Magnetic boom lights. Please see Magnetic Info sheet MM5141 for details.

The Info sheet is attached to this manual if a MIB\* barrier with boom lights was purchased.

Following is a wiring diagram showing the connection of the MLC controller and the MSS1C-100 boom-light controller:

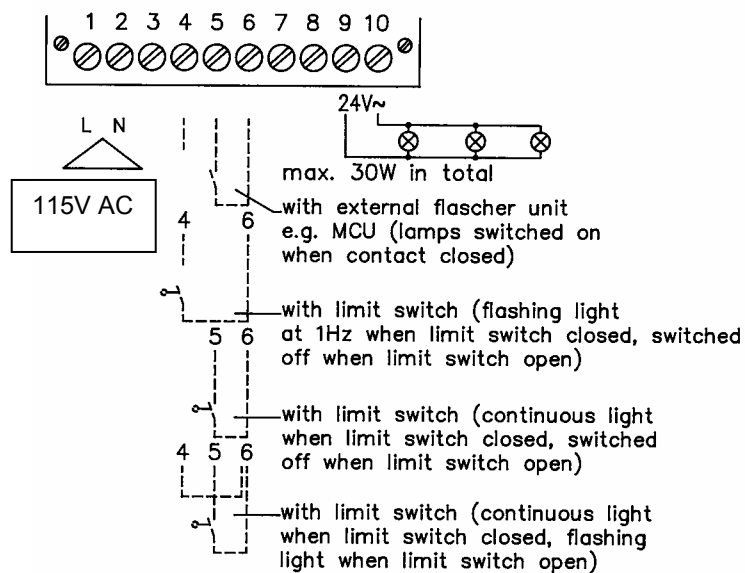
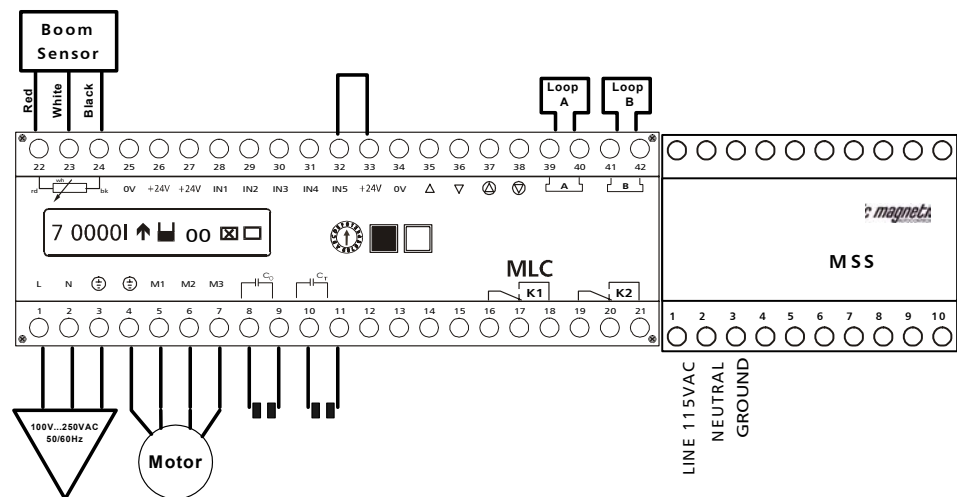

## 20.0 Mechanical operation

The MIB series is based on a unique technology in which the combination of the torque- motor springs and sinusoidal lever system assures a reliable mechanical operation. This technology together with the MLC controller and the boom-positioning sensor will operate the barrier very reliably without bouncing the arm in the end positions.

The MIB\* series barrier gates are equipped with two (2) rubber end stops to absorb the shock generated by the moving gate hitting the end positions.

### 20.1 Spring balance

The MIB series barriers are provided with springs to balance the weight of the barrier arm. Ex-Factory the springs are set to the ordered boom length. In some cases, the boom arm must be cut on side or weight has been added to the arm (Signage). Adding or lowering the weight of the arm will influence the balance of the springs.

The possible boom length depends on what type of barrier you choose; following table shows the maximum boom length

Barrier Type	Maximum boom Length*
MIB30	12 ft octagonal aluminum boom, 12 ft articulated boom
MIB40	20 ft octagonal aluminum boom, 15 ft articulated boom

\* The maximum boom lengths refer to the Magnetic Automation Corp. manufactured boom models MSB5N-025 (8ft), MSB5N-030 (10ft), MSB5N-035 (12 ft), MSB5N-045 (15ft), MSB5N-060 (20 ft), MSB5K-025 (8ft articulated), MSB5K-030 (10ft articulated), MSB5K-035 (12ft articulated) and MSB5K-045 (15ft articulated).

In order to balance the arm to the springs follow these steps:

1. Remove the top housing cover
2. The springs are located on the back of the drive unit (see drawing below)

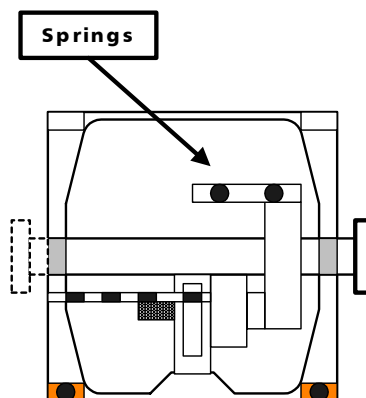

3. Each boom length requires different spring tension and therefore different quantities of springs (see table below)

Boom Length	MIB30	MIB40
MSB5N -025 8FT ALUMINUM OCTAGONAL	2	
MSB5N -030 10FT ALUMINUM OCTAGONAL	3	
MSB5N -035 12FT ALUMINUM OCTAGONAL	4	2 (STRONG SPRINGS, YELLOW MARK)*
MSB5N -045 15FT ALUMINUM OCTAGONAL	N/A	4 (STRONG SPRINGS, YELLOW MARK)*
MSB5N-060 20FT ALUMINUM OCTAGONAL	N/A	6 (STRONG SPRINGS, YELLOW MARK)*
MSB4B-030 10FT ROUND ALUMINUM BOOM	3	N/A

\* The MIB40 uses a springs that have a higher tension than the MIB30's. The MIB40 springs are marked with yellow paint on each of the ends.

**The above table does not apply to articulated barrier arms (Part# MSB5K-025/030/035/045). All Magnetic Automation Corp. articulated barrier arms are custom made to specifications provided by the client. The differences in the lane clearance height influence the weight of the barrier arm and therefore each articulated arm must be adjusted to the individual barrier.**

4. In order to balance the springs you have to move the barrier arm to a 45° angle. The gate arm is balanced when it stays at this position without any electrical power applied to the gate.
5. If the arm moves down, the springs are too weak; if it moves up the springs are too tight.
6. To adjust the springs to the correct tension, remove the plastic clips that hold the adjustment screws in place. Turn the adjustment screws to raise or lower the springs (raise= higher tension, low= lower tension) until the arm is balanced.
7. After balancing the arm, replace the plastic spring clips.
8. Replace the housing lid and turn the power on.
9. Now the controller brake needs to be set to the new settings. Follow instructions in chapter 22.1 to re-adjust the gate arm brake settings.

## 20.2 Barrier arm support

Barrier arm length exceeding 14ft require a support of the boom arm in the lower end position to cushion the arm when it travels in the down position. Magnetic Automation Corp. offers two options of barrier arm supports:

### 20.2.1 Pendulum support

The pendulum support (Part# 1043.0138) is mounted to the barrier arm via two Allen head bolts (see drawing below).

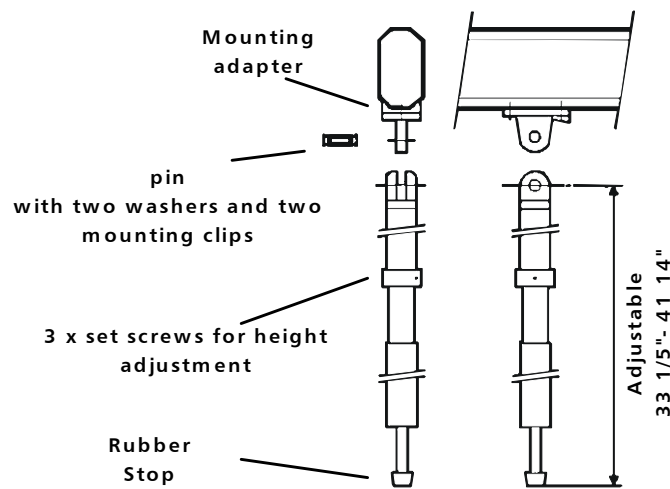

**Note:**

Depending on roadway conditions, the pendulum might have to be lengthened or shortened. To change the length of the support loosen the three set screws located on the center ring of the rod and turn the bottom cylinder clockwise to lengthen or counter clockwise to shorten the support. When the gate arm is in the down position, the distance between the rubber stop and the beginning of the tube should be at about 14". This results in a good damping effect and prevents the rubber from freezing to the tube in cold climate. After the proper length has been adjusted, tighten the three set screws again.



### 20.2.2 Support Post

The support post (Part# MAP5N-110) is mounted to the ground on the end of the gate arm. The arm drops into the cradle when the barrier is in the down position (see drawing)

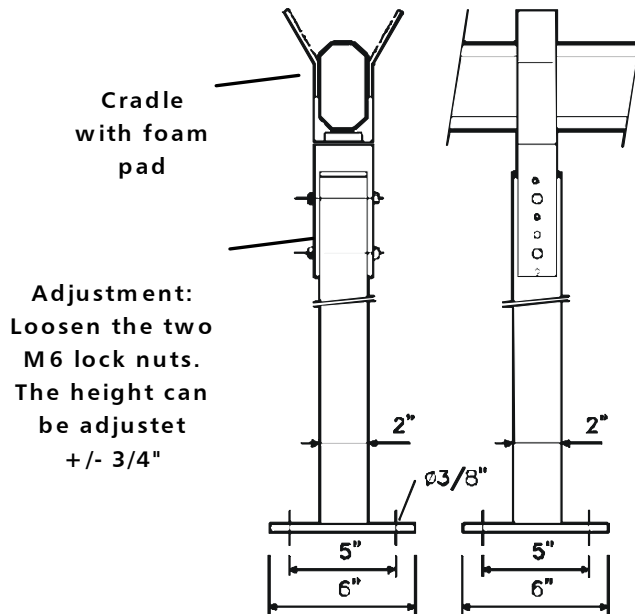

**Note:**

The height of the support post can be adjusted to compensate differences in height between the barrier and the support post foundation.



## 21.0 Troubleshooting

### 21.1 Adjusting the boom position sensor

In case the barrier lost its current position or if a new MLC\* controller must be installed in an existing barrier the display message “ADJUST SENSOR!” will appear on the display.

If this is the case, please follow these steps:

1. Display message:

ADJUST SENSOR !

- 2.0 Make sure the gate arm is in the up position.

3.0 To bring the controller to the sensor adjust mode, turn the rotary switch to position 1, then press and hold the black button while returning the rotary switch to position 0.

Display Message:

SENSOR      XXXX

XXXX = The displayed value should be between 555 and 585. Depending what gate type is installed. See Table below for values.

Gate Type	Sensor Value Up	Sensor Value down
MIB30	0555 - 0580	0105 – 0135
MIB40	0555 - 0580	0105 – 0135

4.0 Push the black and the white button simultaneously. The display shows the MIB20 barrier with 50Hz motor winding first.

Display Message:

MIB20      50 Hz

MIB20 = Gate type  
50 Hz = Line Voltage Frequency

5.0 To select the installed gate model press the back button until you reach the correct model on the display. If you are not certain which gate is installed, close the fold down controller board. The gate type is written on the serial number label on the left upper side of the closed controller mounting board.

Display message	Gate Type
MIB30 50Hz	MIB30*-A100 (230VAC, 50Hz)
MIB30 60Hz	MIB30*-C100 (115VAC, 60Hz)
MIB40 50Hz	MIB40*-A100 (230VAC, 50Hz)
MIB40 60Hz	MIB40*-C100 (115VAC, 60Hz)

6.0 When the correct gate type is displayed press the white button to confirm the setting.

Display Message:

Close barrier ?

7.0 Pressing the black and the white button simultaneously will close the barrier.

**Attention: The gate arm will now close with full torque. Make sure nothing is in its way. If the boom length is longer than 14 ft, please make sure the pendulum support is in place.**

Display Message:

Please wait XXXX

XXXX = The displayed value should be between 120 and 135, depending what gate type is installed. See Table above for values.

8.0 The controller is now testing if the down position is within the preset limits (see table on previous page). When finding the correct position, the following is displayed.

Display Message:

Open barrier ?

9.0 When pressing the black and the white button simultaneously the barrier will start to open.

**Attention: The gate arm will now open with full torque. Make sure nothing is in its way. If the boom length is longer than 14 ft, please make sure the pendulum support is in place**

Display Message:

Please wait XXXX

XXXX = The displayed value should be between 555 and 580, depending what gate type is installed. See Table above for values.

10.0 The controller is now testing if the up position is within the preset limits (see table). When finding the correct position the following is displayed.

Display Message:

Sensor Adjusted

11.0 The position sensor is now adjusted. Based on this adjustment the controller must now find the optimum **brake** points for the gate type and the boom length. To do so press the black and the white button simultaneously.

Display Message:

Close barrier ?

12.0 When pressing the black and the white button simultaneously the barrier will start the brake adjustment procedure. During this adjustment, the gate will open and close until it finds the optimal brake points. This procedure may take up to 5 minutes depending on gate type and boom length.

**Attention:** The gate arm will now cycle up and down. Make sure nothing is in its way. If the boom length is longer than 14 ft, please make sure the pendulum support is in place.

13.0 After the gate arm found the optimum brake points following is displayed.

Display Message:

Brake Adjusted

14.0 The controller has now found the optimum brake points for this barrier. To return to the normal operation turn the rotary switch to position 1 and then back to 0.

15.0 After this process, the controller settings must now be set to suit the requirements for this installation: Program Mode (see chapter 5.0), Loop Mode (see chapter 9.0).

16.0 After the settings have been done, return the rotary switch to position 0 for normal operation.

## 21.2 Boom Sensor out of adjustment

If the procedure explained in chapter 22.1 does not solve the problem or if the display keeps flashing when the barrier is trying to find its end position, the position sensor is out of adjustment. Following table shows the correct position value for the gates

Gate Type	Sensor Value Up	Sensor Value down
MIB30	0555 - 0580	0120 – 0135
MIB40	0555 - 0580	0120 – 0135

To re-position the sensor to the correct position please follow these steps:

- 1.0 Move gate to the complete up position
- 2.0 Turn rotary switch to position 1, then press and hold both the black and the white button while returning the rotary switch to position 0.

Display Message:

SENSOR      XXXX

XXXX = The displayed value should be between 555 and 585. Depending what gate type is installed.

- 4.0 The sensor must now be physically adjusted. The sensor is located on the opposite side of the drive shaft (see picture).

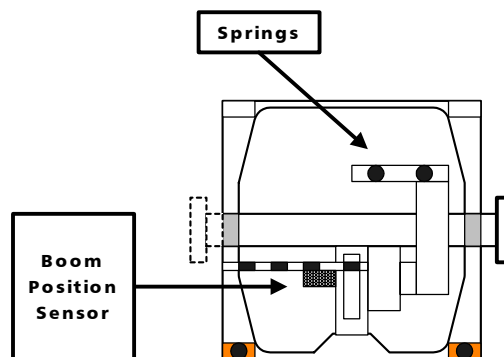

- 5.0 The sensor is attached to the drive shaft via a 5mm set screw. Use a 2.5mm hex key (Allen Wrench) to loosen the set-screw (do not remove it completely).

- 6.0 After loosening the stud screw, you are now able to pull the sensor out.

- 7.0 While closely monitoring the numbers on the controller display, turn the shaft in the required direction. When the correct value is displayed (see table on previous page) return the sensor back into drive shaft and tighten the setscrew.

8.0 Recheck that the sensor value on the controller has not changed after tightening the setscrew. If the sensor value is within the limits press the black and the white button simultaneously to start the self-adjusting process.

The display shows the MIB20 barrier with 50Hz motor winding first.

Display Message:

MIB20 = Gate type  
50 Hz = Line Voltage Frequency

MIB20 50 Hz

9.0 To select the installed gate type press the black button until you reach the correct gate type on the display. If you are not certain which gate is installed close the fold down controller board. The gate type is written on the serial number label on the left upper side of the closed controller mounting board.

10.0 When the correct gate type is displayed press the white button to confirm the setting.

Display Message:

Close barrier ?

11.0 Pressing the black and the white button simultaneously the barrier will start to close.

Attention: The gate arm will now close with full torque. Make sure nothing is in its way. If the boom length is longer than 14 ft, please make sure the pendulum support is in place.

Display Message:

Please wait XXXX

XXXX = The displayed value should be between 120 and 135, depending what gate type is installed. See Table above for values.

12.0 The controller is now testing if the down position is within the preset limits (see table). When finding the correct position, the following is displayed.

Display Message:

Open barrier ?

13.0 When pressing the black and the white button simultaneously the barrier will start to open.

**Attention: The gate arm will now open with full torque. Make sure nothing is in its way. If the boom length is longer than 14 ft, please make sure the pendulum support is in place**

Display Message:

Please wait XXXX

XXXX = The displayed value should be between 555 and 580, depending what gate type is installed. See Table above for values.

14.0 The controller is now testing if the up position is within the preset limits (see table). When finding the correct position the following is displayed.

Display Message:

Sensor Adjusted

15.0 The position sensor is now adjusted. Based on this adjustment the controller must now find the optimum brake points for the gate type and the boom length. To do so press the black and the white button simultaneously.

Display Message:

Close barrier ?

16.0 When pressing the black and the white button simultaneously the barrier will start the brake adjustment procedure. During this adjustment, the gate will open and close until it finds the optimal brake points. This procedure may take up to 5 minutes depending on gate type and boom length.

**Attention: The gate arm will now cycle up and down. Make sure nothing is in its way. If the boom length is longer than 14 ft, please make sure the pendulum support is in place.**

17.0 After the gate arm finds the optimum brake points following message is displayed.

Display Message:

Break Adjusted

18.0 The controller has now found the optimum brake points for this barrier. To return to the normal operation turn the rotary switch to position 1 and return it to 0 for normal operating mode.

### 21.3 Loop Detector error

The MLC controller is equipped with a loop detector diagnostic feature. If there is a loop error, it will be displayed on the controller display.

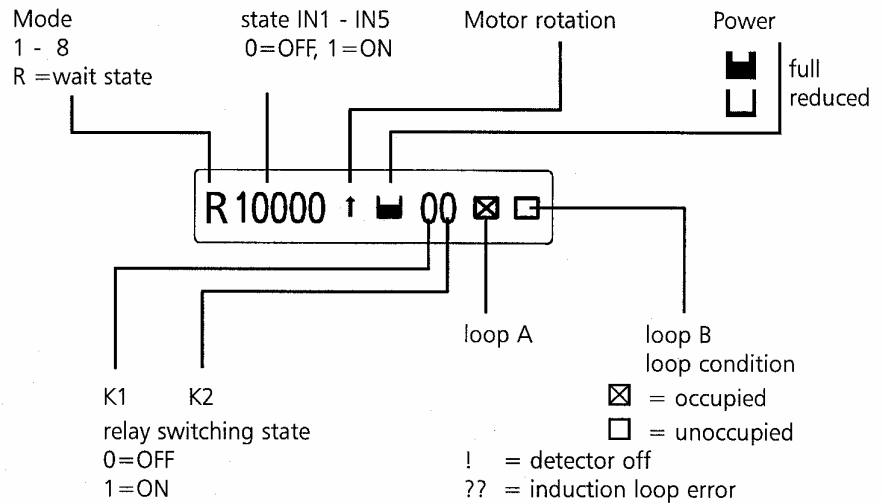

Following are the detector status display:

- A rectangular box means that this loop detector is activated and the loop is connected and read properly.
- A rectangular box with a cross means that this loop detector is activated and a vehicle is present on the loop.
- ! An exclamation mark means that the loop is not activated.



A question mark means that there is a loop failure or the loop is not connected.



A line at the Loop A display and a question mark at loop B means that loop A is detected but Loop B has a failure or is not connected.



A line at the Loop B display and a question mark at loop A means that loop B is detected but Loop A has a failure or is not connected.

### Note:

If any of the above error messages appear, please make sure that



- a. The loop is connected at all
- b. The Loop is connected to the proper terminals
- c. The Loop has the correct turns and is laid out properly
- d. The loop has the correct insulation resistance to earth.
- e. That you disabled the loop detectors that are not used.

Please see chapter 16.0 for more details. If you require more detailed information regarding loop installation and Magnetic Automation's loop detectors please ask for the newest **INDUCTIVE LOOP DETECTOR MANUAL**.

## 21.4 Gate does not close

There can be different reasons for why the barrier is not closing. Following are a few examples:

### 1. Barrier does not go all the way down:

Reason:

**A:** Make sure that the barrier arm is attached to the gate. The MIB barrier arms are balanced with springs, without the weight of the arm the motor is not able to close the barrier.

**B:** The spring tension is too strong. Ex-Factory the gate is adjusted for the ordered boom length. If for any reason, the arm is shorter then adjusted ex factory the springs need to be readjusted to balance the new weight of the shorter boom. See chapter 22.6 for more details.

### 2. Barrier does not react to any closing inputs

Reason:

**A:** Make sure that input IN5 is made. IN5 is the safety input for external safety devices other than induction loops connected on Loop A. If Loop A is activated, input IN5 must be made (jumper wire terminal 32-33 delivered ex-factory). If an external safety device is used (for example: Photo Beam) the normally closed contact of this device must be connected to this terminal. If Input IN5 is not made the gate will not close.



**B:** Make sure that safety device, externally connected on IN5 (if used) or the internal safety loop A is not triggered. The barrier will not close if the safety device is activated.

**C:** If the gate should close by passing through the safety device, please check if the safety device is actually being triggered when a vehicle drives through the safety zone. If Loop A is used for safety/closing check if a cross appears in the square on the Loop A status display when the vehicle is on the loop. If an external safety/closing device is used, make sure the status display of IN5 displays “0” when the vehicle is on the safety zone and returns to “1” when the vehicle has left. The gate should then close.

**D:** If using the safety/closing loop/device to close the gate, make sure the Program mode is set to 5, 6, 7 or 8 (see chapter 5.0 for more details).

**C:** If you are, using inputs to close the barrier make sure you connected it to the correct terminals in respect to the program modes (see chapter 5.0 for more details).

**Note:**

**In any case; if the barrier does not open or close try the provided gate UP/NORMAL/DOWN switch first to determine if the problem comes from the gate or the peripheral equipment.**



### 21.5 Gate does not open

There can be several reasons for why the barrier is not opening. Following are a few examples:

**A:** The barrier arm is too heavy. The spring tension is too weak. Ex-Factory the gate is adjusted for the ordered boom length. If for any reason the arm is longer or additional weight was added to it (for example: Stop signs) the springs have to be readjusted to balance the boom arm. The motor is not strong enough to lift the arm if the springs are not balanced with the arm. See chapter 22.6 for more details.

**B:** Make sure the barrier open contact is connected to the correct terminal. See chapter 5.0 for details.

**C:** Make sure that IN3 is not made. This contact has higher priority then IN1. If using IN1 to open the gate IN3 must be off.

**Note:**

**In any case, if the barrier does not open or close try the provided gate UP/NORMAL/DOWN switch first to determine if the problem comes from the gate or the peripheral equipment.**



### 21.6 How to change from right-handed gate to left-handed?

On which side of the housing the boom is positioned and in what relation to the road the housing is positioned determines if the gate is right or left handed. Please see drawing below for further details.

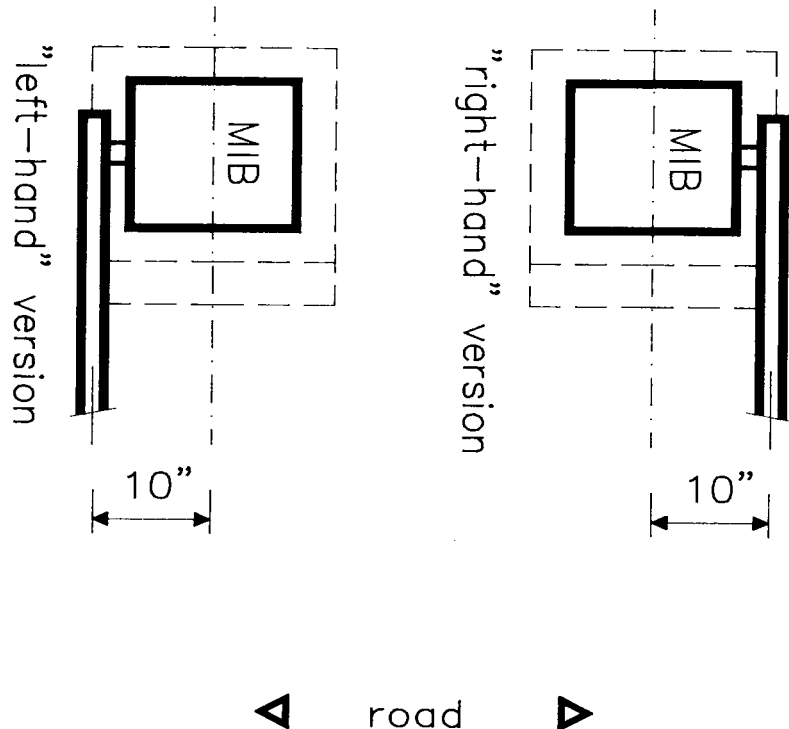

Ex-factory we ship the barrier as ordered, either right or left-handed. If during installation, the barrier has to be changed from right to left handed or vice versa please follow the steps below:

1. Move the barrier to the up position.
2. Turn the electrical power off.
3. Remove the gate arm from the flange.
4. Loosen up or remove the springs (before loosening up the springs please make sure you remember how tight they were when putting them back on).
5. Loosen (do not completely remove) the two Allen bolts that clamp the shaft lever to the shaft.
6. Remove the retainer ring that is holding the shaft in place opposite from the flange.
7. Take off the distance bushings.

8. You can now pull the shaft out of the drive unit frame. Sometimes it is necessary to use a screwdriver or a similar tool to wedge the shaft lever when pulling the shaft out.
9. Slide the shaft into the opposite side all the way through.
10. Replace the distance bushings and the retainer ring.
11. Level the boom flange parallel to the gate housing and retighten the two Allen head bolts.
12. Replace or re-tension the springs to the position in which they originally were.
13. Replace the barrier arm.
14. Turn the power back on.
15. Close the barrier
16. Check the horizontal position of the gate arm to the driveway.
17. If the gate arm is not parallel to the driveway, open up the two Allen head bolts that secure the shaft lever to the shaft and adjust the arm position.
18. When the arm is parallel to the driveway, re-tighten the two Allen head bolts.

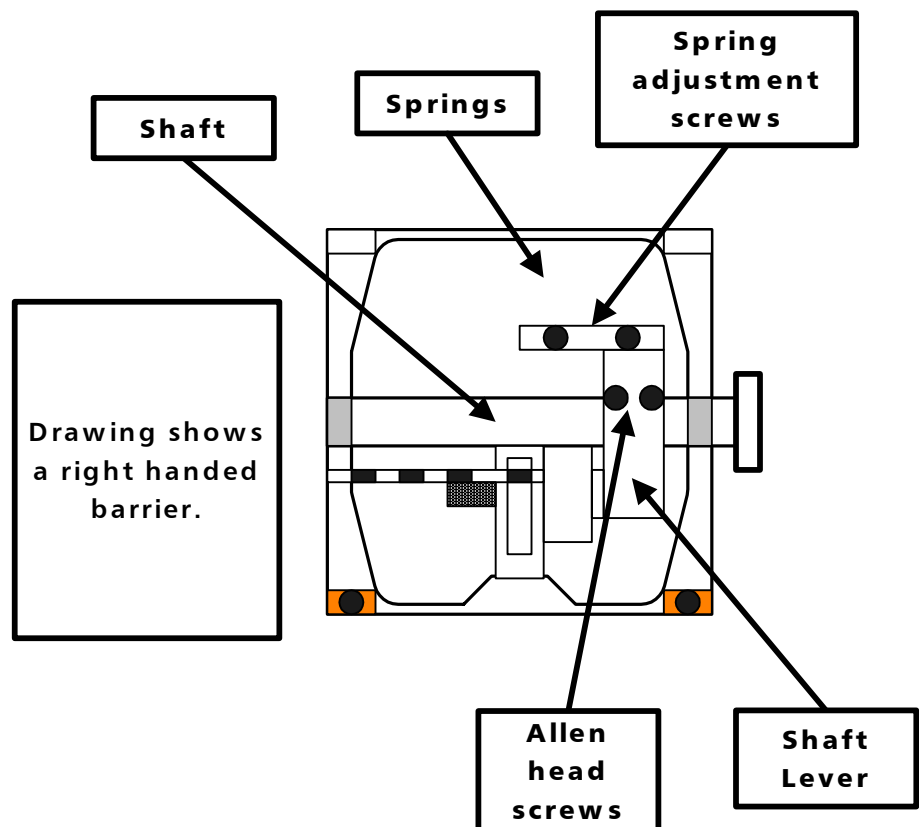

## 22.0 Technical Data

### 22.1 MAGSTOP Barriers

	MIB30	MIB40
Max. Boom length	12FT octagonal	20 FT octagonal
Opening/closing time	1,4 sec	4,0 sec
Power consumption	120 W	120 W
Housing	Zinc-plated sheet steel color powder coated	Zinc-plated sheet steel color powder coated
Housing dimensions (W x D x H)	14" x 14"x 42"	14" x 14"x 42"
Foundation base frame	Stainless steel	Stainless steel
Weight (without arm)	145 lbs.	145 lbs.
Operating temp. Range (Ambient)	-22°F TO +140°F	-22°F TO +140°F
Drive Unit	Torque motor	Torque motor

### 22.2 Controller

	Unit	MLC10
Voltage (+/- 10%)	Volt	100-240
Frequency	Hertz	50 - 60
Max. power consumption	Watt	20
Fuse		F4AH
Control Voltage		24 V DC / max. 300 mA"
No. of inputs		5
No of zero-potential changeover relays	max.250V AC/3A 2	2
No. of open collector outputs	max.50mA/24V DC	2
	Unit	MLC10

Display Characters		16
Choice of languages		D-GB-F-E
No. of loop detectors		2
Induction range	μH	70 - 500
No of sensitivity settings		10
Sensitivity range	%	0.01-2
Protection Class	IP	20
Weight	Lbs	2
Dimensions	Inch (L x W x H)	7.87"x2.95"x4.64"

## 23. Maintenance

The MIB30/40 series barrier gates are designed for a long lifetime with only a minimum of maintenance required.

To guarantee the greatest available equipment uptime and maximize the lifetime of the MIB30/40 series barriers please follow the prescribed maintenance schedules.

Use the Maintenance Service Record, located on page 98, to keep track of your maintenance and upkeep activities on the MIB series barrier models.

### 23.1 Changing the Rubber End Stop

The MIB\* series barrier gates are equipped with two (2) rubber end stops to absorb the shock generated by the moving gate hitting the end positions.

Those rubber end stops need to be replaced once per year or after one million cycles whatever comes first.

### 23.2 Checking the Exterior of Cabinet

Inspect the housing for vehicular damage every six months.

### 23.3 Check the barrier arm and the attachment kit

Inspect the barrier arm for physical damage and check if the barrier arm attachment kit is used properly and all parts are in place and tight. Perform this inspection every six months.

### 23.4 Checking the Loop Detectors and Loop Wires

Check the frequencies of the loops every six months. The loop wires should be replaced approximately every four years or as needed. Check the loop sealant every year for cracks or peeling. Replace if needed.

### 23.5 Check safety signage

Inspect for proper attachment of all safety related signage such as Gate Cabinet and barrier arm safety sticker.

## 23.6 Maintenance Service Record

### Maintenance Schedule and Service Record

Gate Model						
Gate Serial Number						
Date Of Installation						
	<b>Minimum</b>	<b>Date</b>	<b>Date</b>	<b>Date</b>	<b>Date</b>	<b>Date</b>
Replace Rubber End Stop	Every year					
Inspect Cabinet	Every 6 months					
Inspect barrier arm	Every 6 months					
Check Loop Frequencies	Every 6 months					
Check Loop Sealant	Every year					
Check/replace Loop wires	Every 4 years					
Replace Gate safety sticker	Every 4 years					

**24. Spare parts**  
MIB 30 / 40

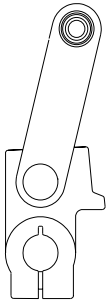

1018,5001  
Motor lever

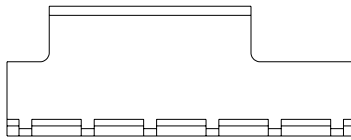

2047,5000  
Upper spring bracket

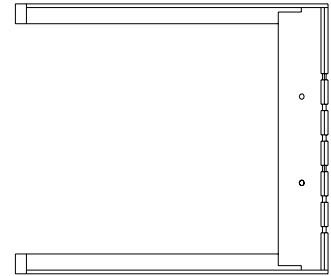

1071,5004  
Lower spring bracket



3004,0001  
Rubber  
End stop

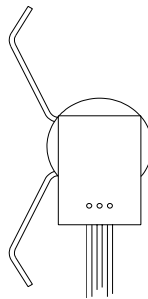

1031,0321  
Potentiometer

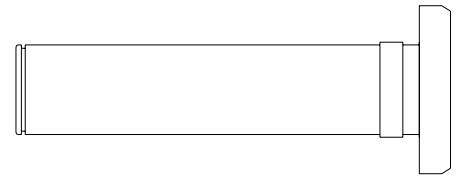

1014,0029  
Flange-shaft

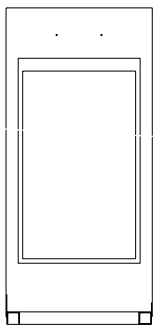

Housing base  
2061,0070 (Orange)  
2061.5027 (White)  
2061.5042 (Yellow)  
2061.5041 (Red)



Housing door  
2043,0152 (Orange)  
2043.5082 (White)  
2043.5097 (Yellow)  
2061.5096 (Red)

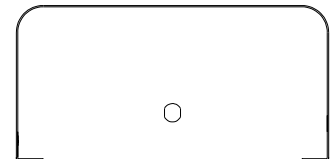

Housing Lid  
2029,0023 (Orange)  
2029.5031 (White)  
2043.5040 (Yellow)  
2061.5039 (Red)



# Operation Instructions



3468,0028  
#18 Lock for hood and door



3004,0005  
Hood bumper

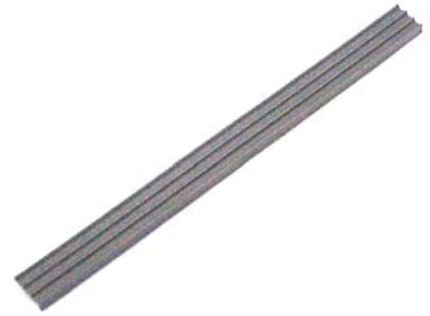

3224,0020  
Door Gasket



3466,0019  
#18 Key



3514,5000  
Wave-ring  
For hood plug



3502,5001  
Distance Ring  
For hood plug



2036,0021  
Spring, strong  
For MIB40 only

Yellow mark →

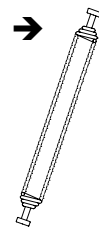

2036,0022  
Spring weak  
For MIB30

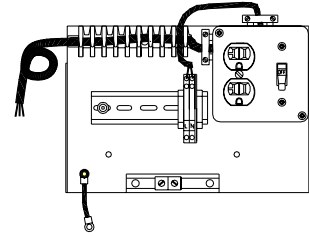
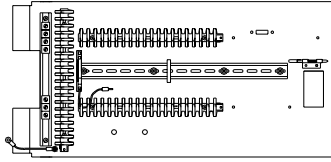
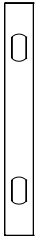

1006,0005  
Capacitor 12 $\mu$ f

1006,0027  
Capacitor 10 $\mu$ f



1031,0180  
Boom attachment kit



1031,0253  
Boom Flange



1031,5055  
Flange-set complete

## Operation Instructions

---



1031,5052  
Octagonal swing away flange-set



1031,0282  
Round boom swing away flange set



1031,5037  
Wood boom flange set

Notes:



Magnetic Automation Corp.  
3160 Murrell Road  
Rockledge, FL 32955

Phone: 321-635-8585  
Fax: 321-635-9449  
E-Mail: [info@magnetic-usa.com](mailto:info@magnetic-usa.com)  
Web: <http://www.ac-magnetic.com>

For Sales and Service, Contact Your Local Magnetic Automation Corp.  
Distributor: